



**BHF**  
Beckmann-Fleige Hydraulik



4 Single Acting Cylinders



6 Aluminium Cylinders



7 Lock-Nut Cylinders



8 Flat Body Cylinders



9 Flat Body Cylinder Kits



10 Low Profile Cylinders



11 Low Profile Cylinder Kit



12 Threaded Cylinders



13 Pull Cylinders



14 Hollow Cylinders



15 Double Acting Hollow Cylinders



16 Double Acting Cylinders



17 Double Acting High Tonnage Cylinders



18 Double Acting High Precision Cylinders



19 Hydraulic Hand Pumps



20 Hydraulic Hand Pumps (Manual Control Valve)



**21 Air Hydraulic Pumps**



**22 Rotary Air Pumps**



**23 Electric Pumps**



**24 Electric Pumps With Solenoid Valve**



**25 Combustion Engine Pumps**

Pumps/Cylinders:  
Operation and  
Speed Charts



**26 Mini Jacks, Toe Jacks and Spreaders**



**27 Pullers and Puller Kit for Single Acting Cylinders**



**29 Pullers for Hollow Cylinders**



**31 Presses**



**32 Electrical Presses**



**33 Hydraulic Accessories Couplers and Hoses**



**34 Manifolds, Gauges and Fittings**



**35 Valves**



**36 Pump Mounted Manifold Block and Remote Valves**



**37 Cylinder Accessories**



**38 Fittings**



## Single Acting Cylinders

- ◆ Heavy Duty Return Spring for quicker retraction.
- ◆ Solid steel cylinder body.

Model Number	Stroke (mm)	A		B		Oil Capacity (cc)	Weight (Kg)
		Min. Height (mm)	Max. Height (mm)	Min. Height (mm)	Max. Height (mm)		
<b>CYLINDER CAPACITY: 5 TON = 45 kN</b>							
H0501		116	142	18	1.4		
H0503	78	169	247	50	1.6		
H0505	129	221	350	83	2.1		
H0507	180	272	452	116	2.3		
H0509	231	323	554	149	2.5		
<b>CYLINDER CAPACITY: 10 TON = 101 kN</b>							
H1001	25	92	117	36	1.8		
H1002	51	123	174	73	2.3		
H1004	102	174	276	147	3.1		
H1006	151	250	401	218	4.3		
H1008	202	301	503	291	5.4		
H1010	253	352	605	365	6.4		
H1012	305	403	707	438	6.8		
H1014	356	450	808	514	7.5		
<b>CYLINDER CAPACITY: 15 TON = 142 kN</b>							
H1501	25	124	149	51	3.3		
H1502	51	149	200	103	3.9		
H1504	101	200	301	204	5.1		
H1506	152	270	422	308	7.0		
H1508	203	321	524	411	8.0		
H1510	254	372	626	515	9.3		
H1512	305	423	728	618	10.9		
H1514	356	474	830	721	11.8		
H1516	407	529	936	824	12.8		
<b>CYLINDER CAPACITY: 25 TON = 232 kN</b>							
H2501	26	143	169	86	6.1		
H2502	51	168	219	169	6.6		
H2504	102	219	321	338	8.7		
H2506	155	272	427	514	10.5		
H2508	206	323	529	683	12.3		
H2510	257	374	631	852	14.0		
H2512	310	426	736	1028	15.3		
H2514	362	478	838	1201	17.7		
<b>CYLINDER CAPACITY: 30 TON = 287 kN</b>							
H3008	210	387	589	879	18.5		
<b>CYLINDER CAPACITY: 50 TON = 496 kN</b>							
H5502	51	176	227	361	15.5		
H5504	101	227	328	715	19.3		
<b>CYLINDER CAPACITY: 50 TON = 496 kN (INCL. 2 CARRY HANDLES)</b>							
H5506	158	283	441	1119	23.5		
H5510	260	384	644	1845	34.0		
H5513	337	481	798	2388	38.8		
<b>CYLINDER CAPACITY: 75 TON = 720 kN (INCL. 2 CARRY HANDLES)</b>							
H7508	158	286	441	1620	30.6		
H7513	333	492	825	3458	52.4		
<b>CYLINDER CAPACITY: 100 TON = 998 kN (INCL. 2 CARRY HANDLES)</b>							
H10002	51	219	270	677	31.5		
H10006	168	357	525	2229	52.4		
H10010	260	449	709	3451	68.7		

High Tonnage Cylinders  
up to 1000 Ton  
available on Request!



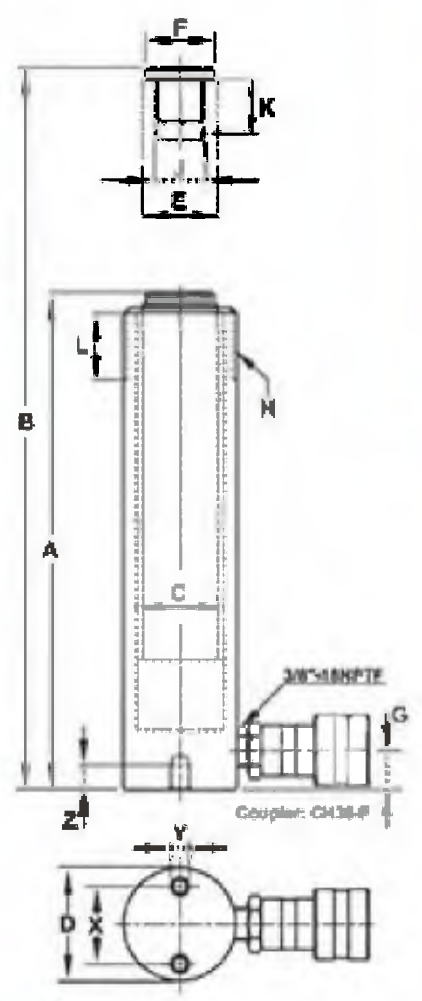

	Capacity kN	Cylinder Effective Area (cm <sup>2</sup> )	C	D	E	F	G	H	L	J	K	Base Mounting Hole		
			Bore Ø (mm)	Outside Ø (mm)	Plunger Ø (mm)	Saddle Ø (mm)	Base to Inlet Port (mm)	Plunger Collar Thread	Plunger Thread Length (mm)	Thread	Thread Length (mm)	Pitch (mm)	Thread	Thread Depth (mm)
<b>5 Ton</b>	45	6.4	29	38	25	25	20	1 1/2"-16UN	29	3/4"-16UNF	16	25	1/4"-20UNC	14
<b>H1001</b>	101	14.5	43	57	38	N/A	20	2 1/4"-14UNC	29	10-24UNC	6	40	5/16"-18UNC	14
<b>10 Ton</b>	101	14.5	43	57	38	35	20	2 1/4"-14UNC	29	1"-8UNC	20	40	5/16"-18UNC	14
<b>15 Ton</b>	142	20.3	51	70	41	38	25	2 3/4"-16UN	30	1"-8UNC	25	48	3/8"-16UNC	13
<b>25 Ton</b>	232	33.2	65	85	57	50	25	3 5/16"-12UN	49	1 1/2"-16UN	30	59	1/2"-13UNC	19
<b>30 Ton</b>	287	41.9	73	102	57	50	50	3 5/16"-12UN	49	1 1/2"-16UN	30	N/A	N/A	N/A
<b>50 Ton</b>	496	70.8	95	127	80	70	31	5"-12UN	55	N/A	N/A	95	1/2"-13UCN	19
<b>75 Ton</b>	728	103.9	115	147	95	70	30	5 3/4"-12UN	44	N/A	N/A	N/A	N/A	N/A
<b>H10092</b>	928	132.7	130	159	105	70	38	6 1/4"-12UN	57	N/A	N/A	N/A	N/A	N/A
<b>100 Ton</b>	928	132.7	130	177	105	70	40	6 7/8"-12UN	44	N/A	N/A	140	3/4"-10UNC	25



## Aluminium Cylinders

- ◆ Heavy Duty Return Spring for quicker retraction.
- ◆ Light weight for easy handling.
- ◆ Hard anodized surface.



Model Number	Stroke (mm)	A		Oil Capacity (cc)	Weight (Kg)
		Min. Height (mm)	Max. Height (mm)		
<b>CYLINDER CAPACITY: 20 Ton = 218 kN</b>					
HU2002	50	174	224	155	3.0
HU2004	100	224	324	311	3.7
HU2006	150	274	424	457	4.4
<b>CYLINDER CAPACITY: 30 Ton = 309 kN</b>					
HU3002	50	181	231	220	4.7
HU3004	100	231	331	441	5.4
HU3006	150	281	431	662	6.1
<b>CYLINDER CAPACITY: 50 Ton = 496 kN</b>					
HU5002	50	186	236	354	7.6
HU5004	100	236	336	708	9.1
HU5006	150	286	436	1063	10.7
HU5008	200	336	536	1417	12.3
HU5010	250	386	636	1772	14.0
<b>CYLINDER CAPACITY: 100 Ton = 929 kN</b>					
HU10004	100	271	371	1327	19.8
HU10006	150	321	471	1990	22.1
HU10008	200	371	571	2654	24.4



Capacity	Cylinder Effective Area	C Bore	D Outside	E Plunger	F Saddle	G Base to Inlet Port	Base Mounting Hole			
							X Pitch	Y Thread	Z Thread Depth	
20 Ton	218	31.17	63	85	50.8	39.5	27.5	70	M6	12
30 Ton	309	44.18	75	100	60	39.5	33.5	80	M6	12
50 Ton	496	70.88	95	130	80	70	30.5	110	M6	12
100 Ton	929	132.73	130	180	109.9	70	46.5	160	M6	12

## Lock-nut Cylinders

- Can support the load for a long period of time.
- The lock nut can be adjusted at any point on the stroke of the cylinder to lock the load off.
- Ram and inside housing are nickel plated to prevent rust and corrosion.
- Two overflow ports in the support rings to avoid over extension of the ram.
- Colour indicator to alert the operator of maximum stroke level.
- Maximum working pressure: 700 bar (10,000 psi).

**High Tonnage Cylinders up to 1000 Ton available on Request!**

HLN10012  
Lock Nut Cylinder

Model Number	Stroke	A		Oil Capacity (cc)	Weight (Kg)
		Min. Height (mm)	Max. Height (mm)		
<b>Cylinder Capacity: 50 Ton = 496 kN (Incl. 2 Lifting Eyes)</b>					
HLN5502	50	164	214	354	15.4
HLN5504	100	214	314	708	20.2
HLN5506	150	264	414	1063	25.0
HLN5508	200	314	514	1418	29.9
HLN5510	250	364	614	1772	34.7
HLN5512	300	414	714	2127	39.5
<b>Cylinder Capacity: 100 Ton = 929 kN (Incl. 2 Lifting Eyes)</b>					
HLN10002	50	187	237	663	30.5
HLN10004	100	237	337	1327	38.9
HLN10006	150	287	437	1990	47.3
HLN10008	200	337	537	2654	55.6
HLN10010	250	387	637	3317	64.0
HLN10012	300	437	737	3981	72.4
<b>Cylinder Capacity: 150 Ton = 1470 kN (Incl. 2 Lifting Eyes)</b>					
HLN15002	50	209	259	1005	52.8
HLN15004	100	237	337	1327	38.9
HLN15006	150	309	459	3018	78.8
HLN15008	200	359	559	4021	91.7
HLN15010	250	409	659	5027	104.7
HLN15012	300	459	759	6032	117.6
<b>Cylinder Capacity: 100 Ton = 929 kN (Incl. 2 Lifting Eyes)</b>					
HLNF10002	50	137	187	725	24.5

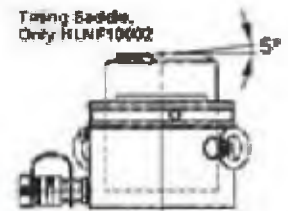
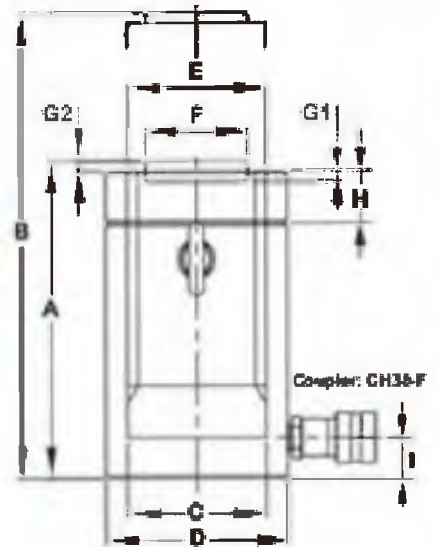

HLNF10002  
Flat Body Lock Nut Cylinder with Tilting Saddle up to 5°

Capacity kN	Cylinder Effective Area (cm²)	C		E	F	G (G1-G2)		G1	G2	H	I
		Bore Ø (mm)	Outside Ø (mm)			Plunger Ø (mm)	Plunger Saddle Depth (mm)				
<b>Lock Nut Cylinders</b>											
50 Ton	496	70.9	95	125	Tw95-6N	70	15	13	2	36	28
100 Ton	929	132.7	130	165	Tw130-4N	70	15	13	2	45	28
150 Ton	1470	201.0	160	205	Tw160-4N	130	15	13	2	44	39
<b>Flat Body Lock Nut Cylinders</b>											
100 Ton	929	145.0	136	175	Tw135-4N	110	N/A	N/A	8	31	21



## Flat Body Cylinders

- Body made of high quality solid steel.
- Extremely low design for use in confined spaces where standard cylinders will not fit.
- Maximum working pressure: 700 bar (10,000 psi).



HF0503  
Coupler: CR38-F

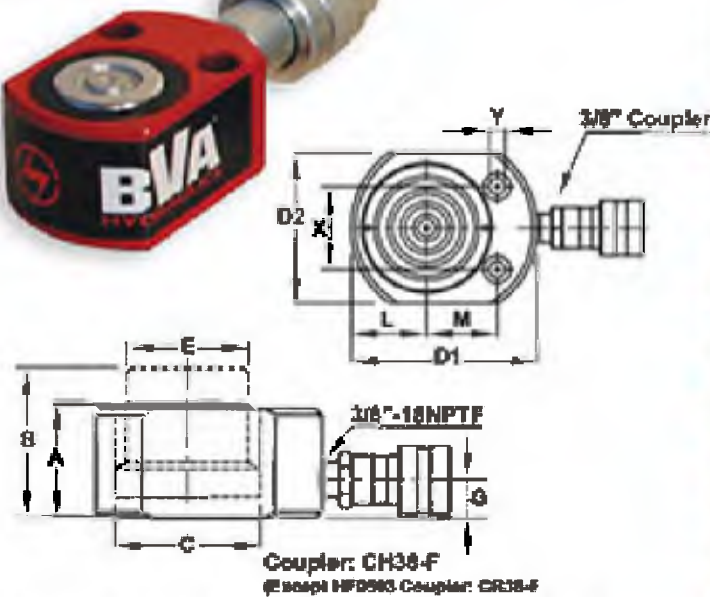

## Incl. 1 Carry Handle

- 75, 100 and 150 Ton Flat Body Cylinders are equipped with a Carrying Handle.



Model Number	Stroke (mm)	A	B	Oil Capacity (cc)	Weight (Kg)
		Min. Height (mm)	Max. Height (mm)		
<b>CYLINDER CAPACITY: 5 Ton = 49 kN</b>					
HF0500	16	41	57	11	0.9
<b>CYLINDER CAPACITY: 6 Ton = 49 kN 3/8\"</b>					
HF0503	6	32	38	4	0.6
<b>CYLINDER CAPACITY: 10 Ton = 104 kN</b>					
HF1005	11	43	54	16	1.5
<b>CYLINDER CAPACITY: 20 Ton = 194 kN</b>					
HF2005	11	51	62	31	2.7
<b>CYLINDER CAPACITY: 30 Ton = 287 kN</b>					
HF3005	13	59	71	54	4.4
<b>CYLINDER CAPACITY: 50 Ton = 445 kN</b>					
HF5006	16	67	83	101	6.7
<b>CYLINDER CAPACITY: 75 Ton = 727 kN (INCL. HANDLE)</b>					
HF7506	16	79	95	168	11.5
<b>CYLINDER CAPACITY: 100 Ton = 887 kN (INCL. HANDLES)</b>					
HF10006	16	85	101	202	14.3
<b>CYLINDER CAPACITY: 150 Ton = 1385 kN (INCL. HANDLES)</b>					
HF15006	16	100	116	316	24.2

Model Number	Capacity kN	Cylinder Effective Area (cm <sup>2</sup> )	C		E	G	L	M	Cylinder Mounting Hole Dimensions			
			Cylinder Bore Ø (mm)	Outside Dim. (mm)					Hole Pitch (mm)	Hole Ø (mm)	Counter Bore Ø (mm)	Counter Bore Depth (mm)
HF0500	49	7.1	30	60 x 40	25	19	20	22	28	5	10	6
HF0503	49	7.1	30	61 x 41	25	19	20	22	28	5	10	6
HF1005	104	15.2	44	84 x 56	38	20	26	34	37	7	10	10
HF2005	194	28.3	60	102 x 76	51	19	39	40	49	10	15	10
HF3005	287	41.9	73	117 x 97	64	20	48	45	52	10	16	11
HF5006	445	63.6	90	140 x 114	70	20	57	54	67	11	19	13
HF7506	727	103.9	115	165 x 140	90	20	70	67	76	13	21	14
HF10006	887	126.7	127	177 x 152	90	20	76	75	76	13	21	14
HF15006	1385	197.9	158	215 x 190	118	24	95	83	117	13	21	14



# Flat Body Cylinder Kits

- Magnetic adapters in various heights.
- Carrying case.
- Adapters: Ideal if you do need additional height in restricted areas.

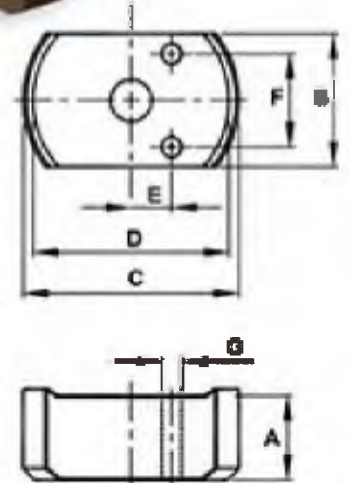

HF0503

Model Number	Cylinder Model	Capacity kN	Stroke (mm)	Oil Capacity (cc)	Min. Height (mm)	Adapter	Adapter Dimensions (mm)							Weight (kg)	
							A	B	C	D	E	F	G		
<b>CYLINDER CAPACITY: 5 Ton = 49 kN</b>															
HF0503	HF0503	49	6	4	32	I	6	41	65	59	12	28	6	2.6	
						II	13								
						III	25								
						IV	32								
<b>CYLINDER CAPACITY: 10 Ton = 104 kN</b>															
HF1005B	HF1005	104	11	16	43	I	10	56	90	82	21	37	7	3.9	
						II	20								
						III	40								
<b>CYLINDER CAPACITY: 20 Ton = 194 kN</b>															
HF2005B	HF2005	194	11	31	51	I	10	76	108	100	27	49	10	7.0	
						II	20								
						III	40								
<b>CYLINDER CAPACITY: 30 Ton = 267 kN</b>															
HF3005B	HF3005	287	13	54	59	I	10	95	121	113	34	52	10	9.4	
						II	20								
						III	40								
<b>CYLINDER CAPACITY: 50 Ton = 445 kN</b>															
HF5005B	HF5006	445	16	101	67	I	10	114	149.5	141.5	41	66.5	11	14.66	
						II	20								
						III	40								



## Low Profile Cylinders

- Compact design for use in confined spaces.
- Plunger wiper reduces contamination and extends the cylinder-life.
- Specially designed return spring ensures a quick retraction and extends the life of the spring.
- Industrial hard chrome plated ram helps to prevent scratching and corrosion.
- Plunger end is grooved to reduce load slipping.
- High flow ball coupler and dust cap included.
- HL1001, HL2002 and HL3002 coupler is tilted upward for added clearance.
- Maximum working pressure: 700 bar (10,000 psi).

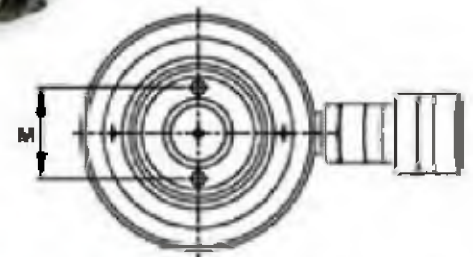
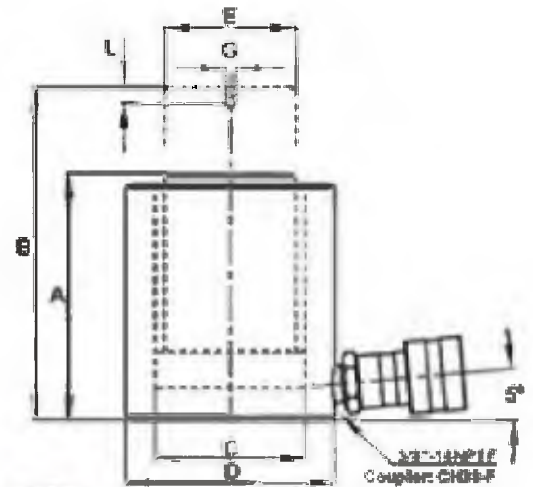

Model Number	Stroke (mm)	A	B	Oil Capacity (cc)	Weight (Kg)
		Min. Height (mm)	Max. Height (mm)		
<b>CYLINDER CAPACITY: 10 TON = 106 kN</b>					
HL1001	38.0	88	126	58	2.6
<b>CYLINDER CAPACITY: 20 TON = 198 kN</b>					
HL2002	44.5	144	179	126	5.0
<b>CYLINDER CAPACITY: 30 TON = 293 kN</b>					
HL3002	62.0	117	179	259	6.8
<b>CYLINDER CAPACITY: 45 TON = 445 kN</b>					
HL5002	60.0	122	182	381	9.9
<b>CYLINDER CAPACITY: 80 TON = 897 kN</b>					
HL10002	57.0	141	198	722	20.6

Model Number	Capacity kN	Cylinder Effective Area (cm <sup>2</sup> )	C	D	E	G	L	M
			Cylinder Bore Ø (mm)	Outside Ø (mm)	Plunger Ø (mm)	Thread	Thread Depth (mm)	Pitch Ø (mm)
HL1001	106	15.2	44	70	38	M4	8	28
HL2002	198	28.3	60	92	51	M5	8	40
HL3002	293	41.8	73	102	63	M5	8	40
HL5002	445	63.6	90	124	70	M5	8	40
HL10002	897	126.7	127	165	90	M8	10	56

## Low Profile Cylinder Kit

- Remove truck wheel with the mini-press.
- Fits between chassis and wheel.



**MINI-PRESS**



**MINI-PRESS HL1001 ADAPTERS**  
Capacity: 10 TON  
Minimum Height: 88mm  
Stroke: 38mm



3 aluminium adapters:  
25mm, 50mm en 75mm.



Metal end-part.  
Height 10mm.



10mm + 88mm  
(98mm)



10mm + 25mm + 88mm  
(123mm)



10mm + 50mm + 88mm  
(148mm)



10mm + 75mm + 88mm  
(172mm)



10mm + 25mm + 75mm + 88mm  
(198mm)



10mm + 50mm + 75mm + 88mm  
(223mm)



10mm + 25mm + 50mm + 75mm + 88mm  
(248mm)

Model Number	Capacity kN	Cylinder Effective Area (cm <sup>2</sup> )	Internal Pressure at Capacity (bar)	C	D	E	G	L	M
				Cylinder Bore Ø (mm)	Outside Ø (mm)	Plunger Ø (mm)	Thread	Thread Depth (mm)	Pitch Ø (mm)
<b>CYLINDER CAPACITY: 10 Ton = 106 kN</b>									
HL1001	106	15	587	44	70	36	M4	6	26

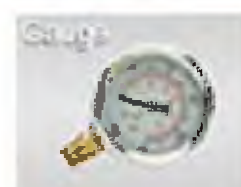

## Threaded Cylinders

- High quality threaded single acting cylinders.
- Removable threaded plunger adapter allows the use of a variety of threaded attachments.
- Used to attach accessories to rod end and base.
- Maximum working pressure: 700 bar (10,000 psi).

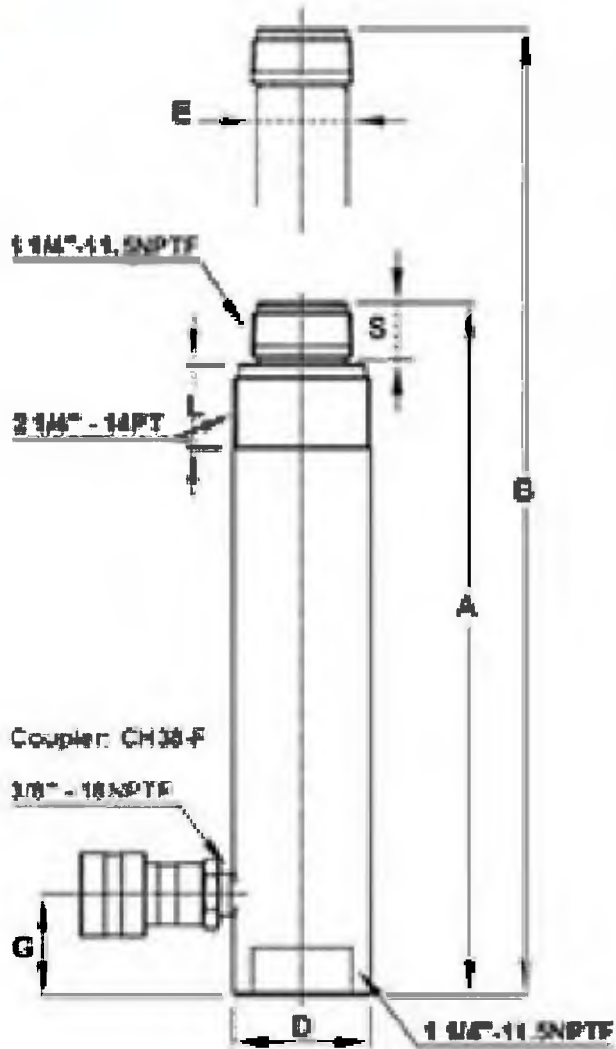

Model Number	Stroke (mm)	A	B	Oil Capacity (cc)	Weight (Kg)
		Min. Height (mm)	Max. Height (mm)		
<b>CYLINDER CAPACITY: 10 Ton = 101 kN</b>					
HT1006	151	291	442	217	4.8
HT1010	253	392	646	365	6.4

High Tonnage Cylinders up to 100 Ton available on Request!

Model Number	Capacity kN	Cylinder Effective Area (cm <sup>2</sup> )	D	E	G	L	S
			Outside Ø (mm)	Plunger Ø (mm)	Base to Inlet Port (mm)	Collar Thread Length (mm)	Saddle Height (mm)
10 Ton	101	14.4	57	38	42	29	27

## Pull Cylinders

- High strength steel construction.
- Guide ring is designed to help protect against side-load damage.
- High lifecycle polyurethane seal.
- External plunger threads.
- Internal base thread for easy attachment.

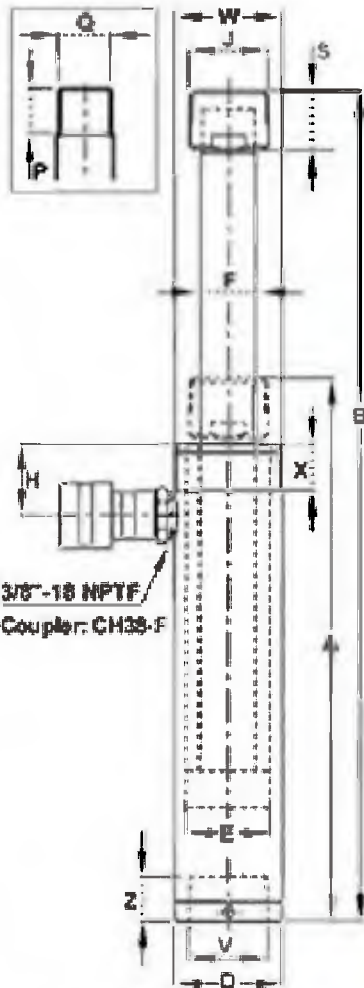

HP1006  
(Clevis CP10: Optional)

High Tonnage Cylinders  
up to 60 Ton  
available on Request!



HP0205



HP0505

PULL CYLINDERS

Model Number	Stroke (mm)	Capacity (kN)	A	B	Oil Capacity (cc)	Weight (Kg)
			Min. Height (mm)	Max. Height (mm)		
<b>CYLINDER CAPACITY: 2.5 TON = 25 kN</b>						
HP0205	127	25	267	394	46	2.0
<b>CYLINDER CAPACITY: 5 TON = 51 kN</b>						
HP0505	141	51	303	444	103	4.2
<b>CYLINDER CAPACITY: 10 TON = 110 kN</b>						
HP1006	151	110	299	450	237	9.5

Model Number	Cylinder Effective Area (cm <sup>2</sup> )	D Outside Ø (mm)	E Cylinder Bore Ø (mm)	H Top to Inlet Port (mm)	J Adapter		F Plunger			W Collar		V Base Mounting Hole	
					Saddle Ø	Thread Length (mm)	Plunger Ø (mm)	Thread Length (mm)	Outside Thread	Thread Ø	Thread Length (mm)	Hole Ø	Thread Length (mm)
HP0205	3.6	48	28	42	3/4"-14NPTF	29	19	19	M16x1.5	1 1/2"-16UN	24	3/4"-14NPTF	18
HP0505	7.4	57	42	38	1 1/4"-11.5NPTF	32	30	24	M28x1.5	2 1/4"-14UN	25	1 1/4"-11.5NPTF	24
HP1006	15.7	85	55	38	-	-	32	26	M30x2	M85x2	25	M30x2	25



## Hollow Cylinders

- Heavy Duty return spring for quicker retraction.
- Dual Plunger wipers help to prevent contamination.
- Collar thread for easy attachment.
- High flow coupler with dust cap.



HOLLOW CYLINDERS

Model Number	Stroke (mm)	A		B		Internal Plunger Thread Lqth (mm)	Oil Capacity (cc)	Weight (Kg)
		Min. Height (mm)	Max. Height (mm)	Min. Height (mm)	Max. Height (mm)			
<b>CYLINDER CAPACITY: 12 Ton = 132 kN</b>								
HC1201T	7.8	60	67	16	15	15	1.5	
HC1202XT	41	120	161	-	77	77	2.8	
HC1202	41	120	161	27	77	77	2.8	
HC1203XT	76	184	260	-	143	143	3.9	
<b>CYLINDER CAPACITY: 20 Ton = 221 kN</b>								
HC2002T	51	162	213	21	161	161	7.2	
HC2006T	154	306	460	21	467	467	13.4	
<b>CYLINDER CAPACITY: 30 Ton = 286 kN</b>								
HC3002T	64	179	243	24	260	260	10.4	
HC3006T	155	330	486	24	633	633	19.5	
<b>CYLINDER CAPACITY: 50 Ton = 589 kN (INCL. 2 CARRY HANDLES)</b>								
HC5003T	76	248	324	21	641	641	29.8	
HC5006T	152	324	476	21	1282	1282	36.8	
<b>CYLINDER CAPACITY: 100 Ton = 1000 kN (INCL. 2 CARRY HANDLES)</b>								
HC10003T	76	254	330	27	1087	1087	51.4	

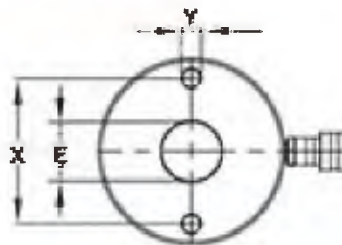

High Tonnage Cylinders up to 1000 Ton available on Request!

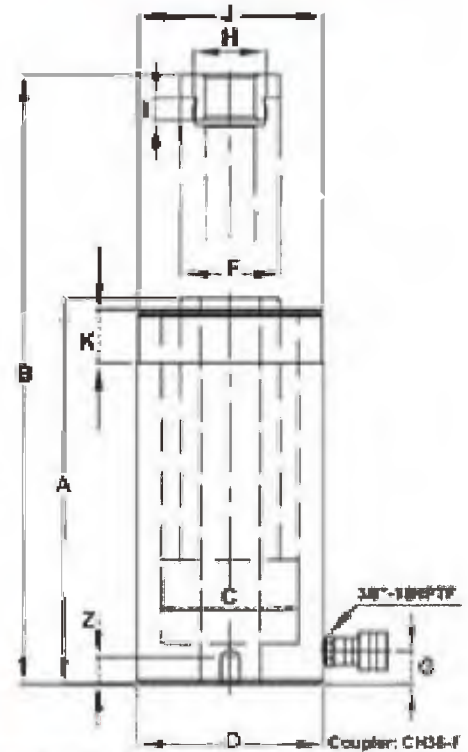

Capacity kN	Cylinder Effective Area (cm <sup>2</sup> )	Cylinder Bore Ø (mm)	Cylinder O.D. (mm)	Plunger				Internal Thread Ø	Collar Thread		Base Mounting Hole		
				I.D. (mm)	O.D. (mm)	Base to Inlet Pkwt (mm)	Ø		Lqth (mm)	Pitch Ø (mm)	Thread Ø	Thread Depth (mm)	
<b>CYLINDER CAPACITY: 12 Ton = 132 kN (COUPLER: CRZ14-F)</b>													
12 Ton	132	18.8	55	70	19	35	15	3/4\"-16UN	2 3/4\"-16	30	50.8	5/16\"-18UNC	9
<b>CYLINDER CAPACITY: 12 Ton = 132 kN (COUPLER: H38-F)</b>													
12 Ton	132	18.8	55	70	19	35	19	3/4\"-16UN	2 3/4\"-16	30	50.8	5/16\"-18UNC	9
<b>CYLINDER CAPACITY: 20 Ton = 221 kN</b>													
20 Ton	316	75	100	127	27	54	19	1 9/16\"-16UN	3 7/8\"-12	38	82.5	3/8\"-16UNC	9
<b>CYLINDER CAPACITY: 30 Ton = 286 kN</b>													
30 Ton	286	40.8	85	114	33	63	23	1 13/16\"-16UN	4 1/2\"-12	42	92	3/8\"-16UNC	14
<b>CYLINDER CAPACITY: 50 Ton = 589 kN (INCL. 2 CARRY HANDLES)</b>													
50 Ton	84.2	125	158	200	27	100	27	2 3/4\"-16UN	6 1/4\"-12	48	130	1/2\"-13UNC	14
<b>CYLINDER CAPACITY: 100 Ton = 1000 kN (INCL. 2 CARRY HANDLES)</b>													
100 Ton	1000	142.8	165	213	33	125	27	4\"-16UN	8 3/8\"-12	60	178	5/8\"-11UNC	19

# Double Acting Hollow Cylinders

- \* Dual Plunger wipers help to prevent contamination.
- \* Collar thread for easy attachment.
- \* High flow coupler with dust cap.

High Tonnage Cylinders up to 1000 Ton available on Request!

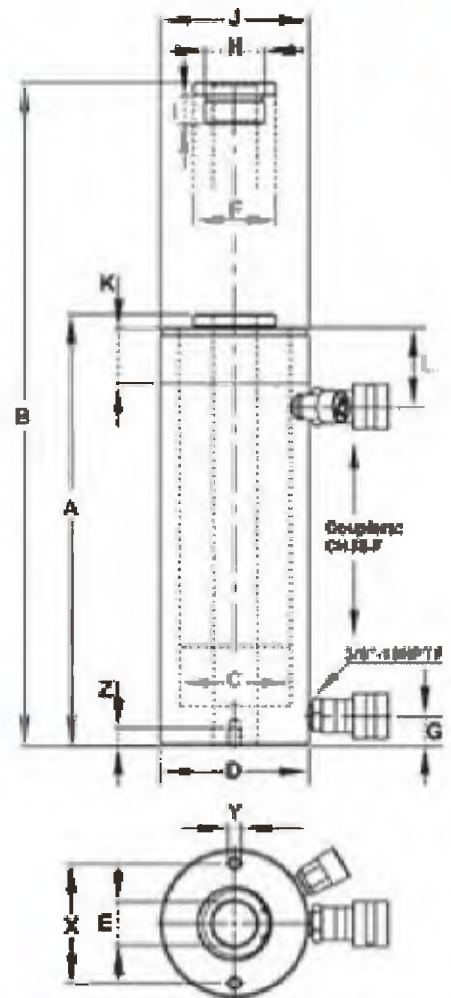

Model Number	Stroke (mm)	A		B		Oil Capacity			L Top to Inlet Port (mm)	Weight (Kg)
		Min. Height (mm)	Max. Height (mm)	In	Out	Push (kN)	Pull (kN)			
<b>CYLINDER CAPACITY: PUSH 10 TON &amp; PULL 13 TON</b>										
HDC3007	177	331	508	725	455	286	179	60.5	19.5	
HDC3010	257	432	689	1049	658	286	179	60.5	24.9	
<b>CYLINDER CAPACITY: PUSH 15 TON &amp; PULL 19 TON</b>										
HDC6003	89	248	337	641	428	589	394	67.0	29.8	
HDC6006	165	324	489	1282	856	589	394	67.0	36.8	
HDC6010	257	438	695	2164	1444	589	394	67.0	31.2	
<b>CYLINDER CAPACITY: PUSH 10 TON &amp; PULL 65 TON</b>										
HDC10001	38	165	203	544	347	1001	638	44.5	33.4	
HDC10003	76	254	330	1087	693	1001	638	86.0	52.7	
HDC10006	152	343	495	2178	1388	1001	638	86.0	68.5	
HDC10010	257	461	718	3678	2345	1001	638	86.0	86.8	

	Cylinder Effective Area		C Cylinder Bore Ø (mm)	D O.D. (mm)	Plunger					J Collar Thread		Base Mounting Hole		
	Push (cm²)	Pull (cm²)			E I.D. (mm)	F O.D. (mm)	G Base to Inlet Port (mm)	H Internal Thread Ø	I Internal Thread Lgth (mm)	Ø	K Lgth. (mm)	X Pitch Ø (mm)	Y Thread Ø	Z Thread Depth (mm)

<b>30 Ton</b>	41	26	85	114	33	63	23	1 1/16"-16UN	17	4 1/2"-12	42.2	92	3/8"-16UNC	14
<b>60 Ton</b>	84	56	125	159	54	92	27	2 3/4"-16UN	17	6 1/4"-12	48.5	130	1/2"-12UNC	14
<b>100 Ton</b>	143	91	165	213	79	125	27	4"-16UN	21	8 3/8"-12	60.5	178	5/8"-11UNC	19

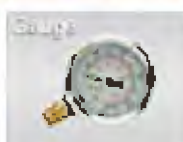

## Double Acting Cylinders

- Internal plunger threads.
- Plunger wiper reduces contamination and extends the cylinder-life.
- High strength steel construction manufactured from solid bar.
- High flow 3/8"-18NPTF couplers.
- Collar thread protectors.
- One piece high grade alloy bearing for side load protection and long life.
- Polyurethane cup seal helps to provide an optimal performance.
- Industrial hard chrome plated ram prevents rust and corrosion.
- Maximum working pressure: 700 bar (10,000 psi).



**High Tonnage Cylinders**  
up to 1000 Ton  
available on Request!

Model Number	Stroke (mm)	A		B		Oil Capacity		Weight (Kg)
		Min. Height (mm)	Max. Height (mm)	Push (cc)	Pull (cc)			
<b>CYLINDER CAPACITY: PUSH 10 TON &amp; PULL 5.4 TON</b>								
HD1010	255	410	665	367	122	12.1		
HD1012	304	458	762	437	145	13.6		
<b>CYLINDER CAPACITY: PUSH 30 TON &amp; PULL 15 TON</b>								
HD3003	207	389	596	867	426	19.5		
HD3014	368	550	918	1541	758	27.5		
<b>CYLINDER CAPACITY: PUSH 50 TON &amp; PULL 25 TON</b>								
HD5008	157	331	488	1113	323	29.4		
HD5013	335	509	844	2375	680	44.6		
HD5020	511	733	1244	3623	1052	63.7		
<b>CYLINDER CAPACITY: PUSH 75 TON &amp; PULL 37 TON (REQUIRES 2 CARRY HANDLES)</b>								
HD7506	155	348	503	1608	511	39.9		
HD7513	333	526	859	3456	1098	59.6		
<b>CYLINDER CAPACITY: PUSH 95 TON &amp; PULL 47 TON (REQUIRES 2 CARRY HANDLES)</b>								
HD10006	167	357	524	2216	1032	60.1		
HD10013	333	524	857	4418	2057	85.2		
HD10018	461	687	1148	6117	2649	110.0		

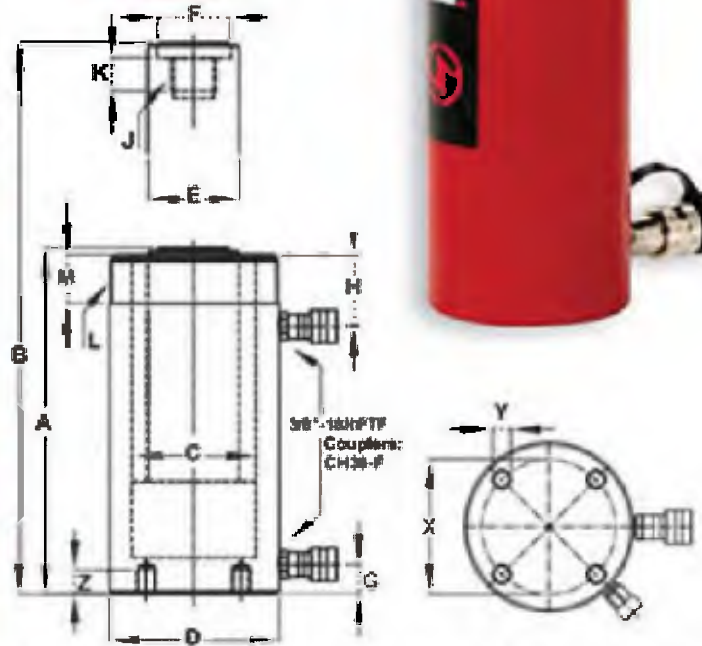

Capacity	Cylinder Effective Area		Cyl. Bore		Plunger		Collar Thread		Base Mounting Hole								
	Push (kN)	Pull (kN)	Push (cm²)	Pull (cm²)	O.D. (mm)	I.D. (mm)	Base Inlet Port (mm)	Top Inlet Port (mm)	Internal Thread (mm)	Internal Thread Lgh (mm)	Internal Thread (mm)	Internal Thread Lgh (mm)	Pitch (mm)	Thread (mm)	Thread Depth (mm)		
	(kN)	(kN)	(cm²)	(cm²)	(mm)	(mm)	(mm)	(mm)	(mm)	(mm)	(mm)	(mm)	(mm)	(mm)	(mm)		
<b>10 Ton</b>	101	34	14	4	43	73	35	35	36	53	1-8UNC	25	2 1/4-14	26	-	-	-
<b>30 Ton</b>	293	144	41	20	73	101	54	50	42	74	1 1/2-16UN	25	3 5/16-12	49	-	-	-
<b>50 Ton</b>	496	144	70	20	95	127	79	70	29	<b>73</b>	1-12UNF	25	5-12	44	-	-	-
<b>75 Ton</b>	726	231	103	33	115	146	95	70	30	71	1-12UNF	38	5 3/4-12	38	-	-	-
<b>100 Ton</b>	928	433	132	61	130	177	95	75	31	75	1 3/4-12UN	35	6 7/8-12	50	139	3/4-10	25.0



# High Tonnage Double Acting Cylinders

- Cylinders are burnish rolled for a smooth precision mirror finish.
- Industrial hard chrome plated ram prevents scratching and corrosion.
- Base mounting holes standard on all models.
- Rod wiper seals out dirt and contamination.
- High strength steel construction from gun drilled solid bar.
- High flow 3/8"-18NPTF couplers.
- Ideal for pushing and pulling.
- Maximum working pressure:  
10,000 psi / 700 bar.

HIGH TONNAGE DA-CYLINDERS



Model Number	Stroke (mm)	A		B		Oil Capacity		Weight (Kg)
		Min. Height (mm)	Max. Height (mm)	Push (cc)	Pull (cc)			
<b>CYLINDER CAPACITY: 95 Ton (Metric)</b>								
HDG10002	50	182	232	664	309	27.7		
HDG10004	100	232	332	1327	618	33.6		
HDG10006	150	282	432	1991	628	39.6		
HDG10008	200	332	532	2655	1237	45.5		
HDG10010	250	382	632	3318	1546	51.5		
HDG10012	300	432	732	3982	1856	57.5		
<b>CYLINDER CAPACITY: 140 Ton (Metric)</b>								
HDG15002	50	196	246	983	506	46.5		
HDG15004	100	246	346	1963	1013	55.3		
HDG15006	150	296	446	2945	1519	64.3		
HDG15008	200	346	546	3926	2025	73.3		
HDG15010	250	396	646	4907	2531	82.3		
HDG15012	300	446	746	5889	3038	91.5		

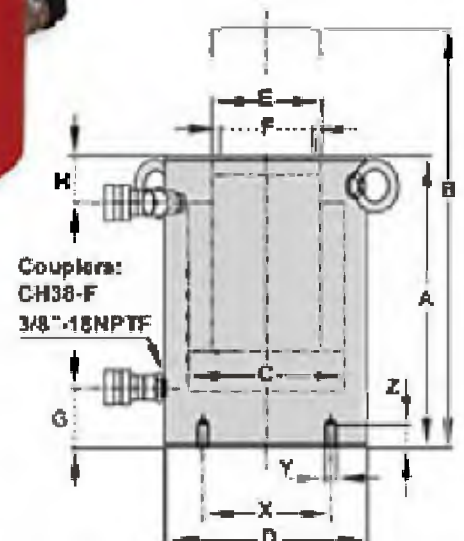

Capacity		Cylinder Effective Area		C	D	E	F	G	H	Base Mounting Hole		
Push (kN)	Pull (kN)	Push (cm <sup>2</sup> )	Pull (cm <sup>2</sup> )	Cyl. Bore Ø (mm)	Outside Ø (mm)	Plunger Ø (mm)	Saddle Ø (mm)	Base to Inlet Port (mm)	Top to Inlet Port (mm)	Pitch Ø (mm)	Thread Ø	Thread Depth (mm)
<b>CYLINDER CAPACITY: 95 Ton</b>												
930	433	132.7	61.9	130.0	165.1	95.0	75.0	54.1	48.0	95.0	M12	22.10
<b>CYLINDER CAPACITY: 140 Ton</b>												
1375	710	196.3	101.3	158.0	205.0	110.0	94.0	61.0	56.4	130.0	M12	22.10

## High Precision Double Acting Cylinders

- Ideal for pushing and pulling applications.
- The best choice for production applications.
- High strength steel construction.
- One piece high grade alloy bearing for side load protection and longer life.
- Polyurethane cup seal helps to provide an optimal performance.
- External plunger threads.
- Internal base threads.
- Maximum working pressure: 700 bar (10,000 psi).

Model Number	Stroke (mm)	A		B		Oil Capacity		Weight (Kg)
		Min. Height (mm)	Max. Height (mm)	Push (cc)	Pull (cc)			
<b>CYLINDER CAPACITY: PUSH 8 TON &amp; PULL 4.5 TON</b>								
HPD0906	155	350	505	175	99	6.6		
HPD0910	257	452	709	291	165	8.4		
<b>CYLINDER CAPACITY: PUSH 15 TON &amp; PULL 7.5 TON</b>								
HPD1606	159	389	548	322	180	10.0		
HPD1610	260	490	750	527	262	12.8		

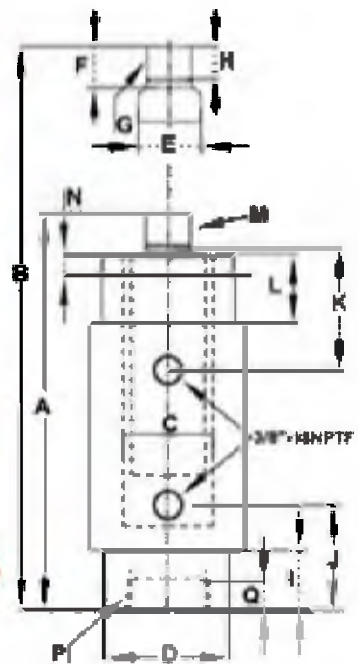

	Max. Cylinder Capacity		Cylinder Effective Area		C Bore Ø (mm)	D Cylinder Outside Ø (mm)	E (mm)	Plunger		H Tread Lgth (mm)	J Base to Inlet Port (mm)	K Top to Inlet Port (mm)	L Lgth (mm)	Collar		P Int. Base Thread Ø	Q Int. Base Thread Length (mm)
	Push (kN)	Pull (kN)	Push (cm²)	Pull (cm²)				F Protru-sion (mm)	G Thread Ø (mm)					M Thread Ø (mm)	N Thread Lgth (mm)		
<b>8 Ton</b>	79	45	11.3	6.4	38	64	25	25	3/4"-16N	19	56	56	38	2"-12N	15	1 11/16"-18N	35
<b>15 Ton</b>	142	71	20.3	10.8	50	76	36	28	1 1/8"-12N	25	73	73	54	2 5/8"-16N	25	2 3/16"-16N	41

## Accessories for High Precision Cylinders

Art. Number for Hydr. Cylinders HPD090x	Art. Number for Hydr. Cylinders HPD160x		
CEBN09	CEBN16		Base Mounting with Retainer Nut
CEFN09	CEFN16		Flange Mounting with Retainer Nut
CEED09	CEED16		Clevis Eye
CEN09	CEN16		Retainer Nut

Model Number	Dimensions						
	A (mm)	B (mm)	C (mm)	D (mm)	E (mm)	F (mm)	H (mm)
<b>CYLINDER CAPACITY: 8 TON</b>							
CEBN09	50.80	101.60	73.15	13.50	25.40	82.50	44.45
CEFN09	50.80	121.00	98.55	10.00	25.40	-	-
CEED09	3/4"-16N	1-1/16"-18N	33.30	19.05	25.40	25.40	23.90
CEN09	2"-12N	76.00	63.50	7.00	12.70	-	-
<b>CYLINDER CAPACITY: 15 TON</b>							
CEBN16	66.80	130.00	95.50	19.50	35.00	101.60	52.30
CEFN16	66.80	143.00	115.80	13.50	35.00	-	-
CEED16	1-1/8"-12N	2-3/16"-16N	47.80	25.40	31.75	25.40	30.20
CEN16	2-5/8"-16N	92.00	79.20	7.00	19.00	-	-

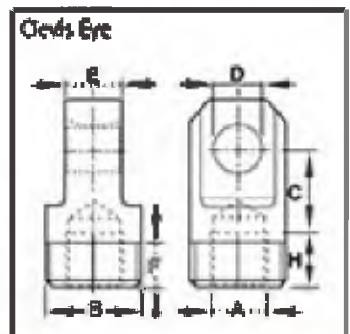
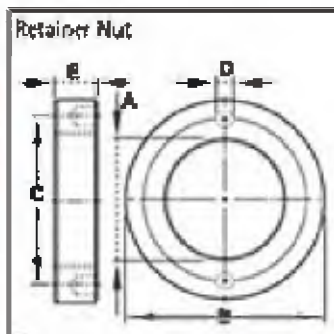
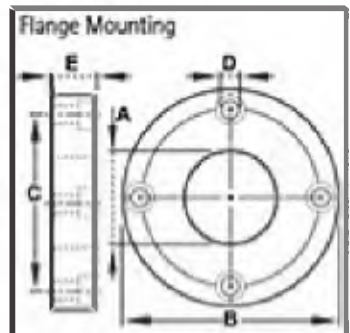
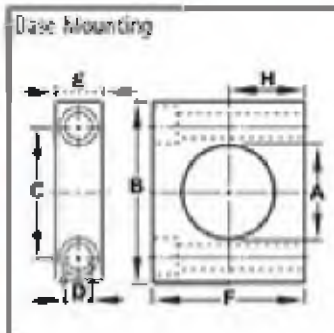

## Hydraulic Hand Pumps

- P350, P1000, P2301, P4301 and P8701 feature two-speed operation which reduces operator fatigue.
- Internal pressure relief valve for overload protection.
- External load release valve for Single Acting Cylinder usage.
- Large oil capacities to power a wide range of cylinders and tools.
- Models P350 and P1000 are constructed of high strength lightweight aluminium alloy for easy handling.
- Maximum working pressure: 10,000 psi / 700 bar.



**Aluminium Reservoir**  
**The Ultra Light Weight**

*P350 and P1000 hand pumps are aluminium and the preferred choice when portability is important.*

HAND PUMPS

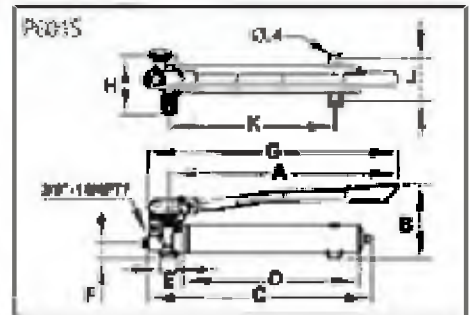
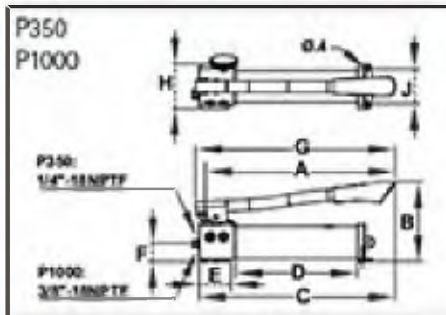
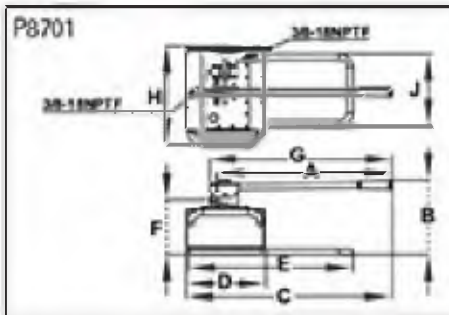

Model Number	A (mm)	B (mm)	C (mm)	D (mm)	E (mm)	F (mm)	G (mm)	H (mm)	J (mm)	K (mm)
P601S	482	160	496	374	40	32	553	132	95	369
P350	344	141	367	227	60	34	362	85	85	-
P1000	552	161	585	377	92	32	576	120	100	430
P1201	552	171	585	552	60	44	552	135	115	446
P2301	525	173	608	597	60	44	552	135	90	573
P4301	525	195	581	589	60	44	552	135	85	545
P8701	655	295	771	293	614	210	684	387	284	-

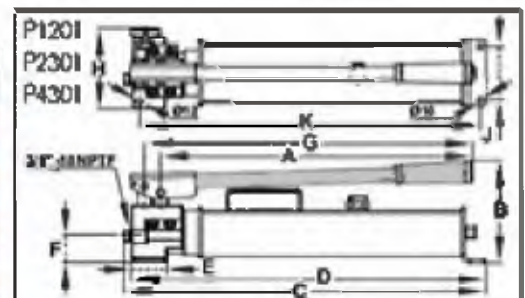

Model Number	Stage	Usable Oil Capacity (cc)	Pressure Rating		Oil Displacement		Max. Operating Force (N)	Piston Stroke (mm)	Oil Outlet Port	Weight (kg)
			1 <sup>st</sup> Stage (bar)	2 <sup>nd</sup> Stage (bar)	1 <sup>st</sup> Stage (cc)	2 <sup>nd</sup> Stage (cc)				
P601S	Single	600	-	700	-	2.46	486	20.0	3/8"-18NPTF	5.9
P350	Two	350	14	700	3.3	0.82	363	10.5	1/4"-18NPTF	3.0
P1000	Two	1000	14	700	13.2	2.30	441	20.7	3/8"-18NPTF	6.2
P1201	Two	1100	14	700	13.2	2.30	441	20.7	3/8"-18NPTF	9.3
P2301	Two	2100	14	700	13.2	2.30	441	20.7	3/8"-18NPTF	12.6
P4301	Two	4100	14	700	13.2	2.30	441	20.7	3/8"-18NPTF	17.0
P8701	Two	7600	20	700	119.8	4.73	637	42.5	3/8"-18NPTF	35.0

## Hydraulic Hand Pumps (Manual Control Valve)

- Internal pressure relief valve for overload protection.
- Large oil capacities to power a wide range of cylinders and tools.
- Maximum working pressure: 700 bar (10,000 psi).
- 4-Way manual control valve for operation of double acting cylinders.



P4301M



P8701M



P2301M

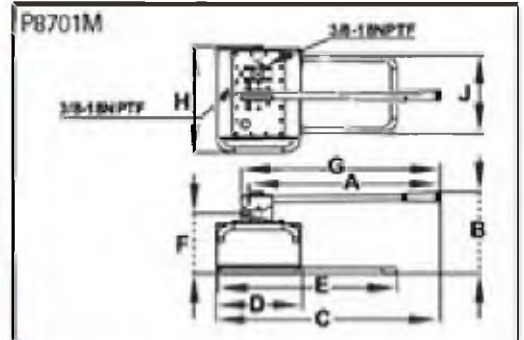
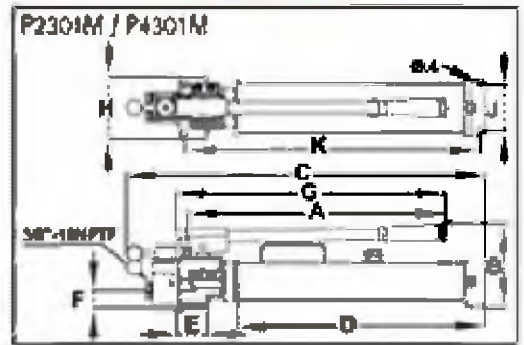

Model Number	A (mm)	B (mm)	C (mm)	D (mm)	E (mm)	F (mm)	G (mm)	H (mm)	J (mm)	K (mm)
P2301M	525	173	693	597	60	38	552	135	90	573
P4301M	525	195	665	569	60	36	552	135	95	546
P8701M	665	295	771	293	614	210	664	387	284	-

Model Number	Stage	Usable Oil Capacity (l)	Pressure Rating		Oil Displacement per Stroke		Max. Operating Force (N)	Piston Stroke (mm)	Oil Outlet Port	Weight (kg)
			1 <sup>st</sup> Stage (bar)	2 <sup>nd</sup> Stage (bar)	1 <sup>st</sup> Stage (cc)	2 <sup>nd</sup> Stage (cc)				
P2301M	Two Speed	2100	14	700	13.2	2.30	440	20.7	3/8"-18NPTF	14.6
P4301M	Two Speed	4100	14	700	13.2	2.30	440	20.7	3/8"-18NPTF	19.0
P8701M	Two Speed	7200	21	700	119.8	4.73	650	42.5	3/8"-18NPTF	35.2

Valve Operation	Valve Type	Use with Cylinder	Hydraulic Symbol	Schematic Flow path			Weight (kg)
Manual	4-way, Tandem Center	Double Acting					1.8



## Air Hydraulic Pumps

- High Strength reinforced alloy aluminium reservoir is lightweight and corrosion resistant.
- Internal pressure relief valve for overload protection.
- Suggested air pressure range: 8-14 bar.
- Designed to be used with single acting cylinders.
- PA1500M and PA3801M are designed to be used with double acting cylinders.
- Dust cover protection for the release control valve.
- Dual stage release valve.
- Model PA2000 features high pressure, high flow performance.
- Maximum working pressure: 700 bar (10,000 psi).
- PA600H same as PA600, but with Hand Operation.



PA1500L

### Remote Control

With the PA1500L and PA3801L a remote control is included.

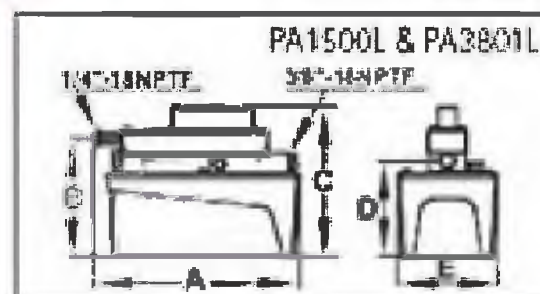
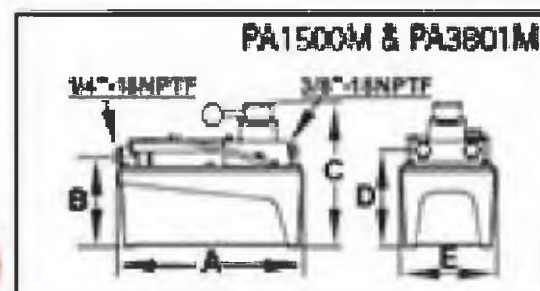
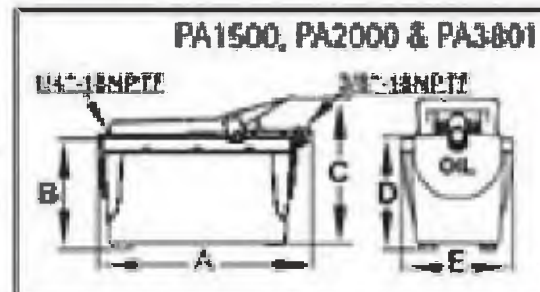
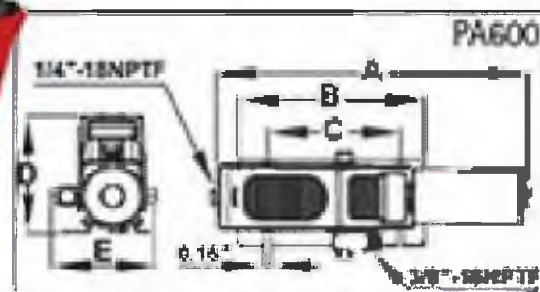
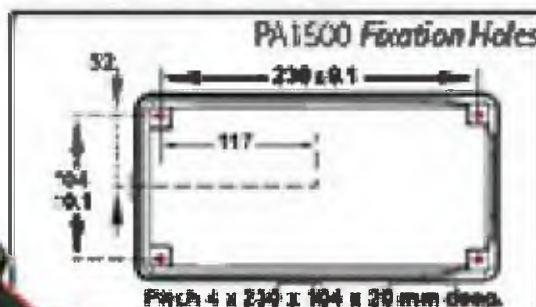

PA1500M

PA1500



PA1500A

Pressure Rating (BAR)	Air Pressure Range (BAR)	Air Input Port	Oil Output Port
<b>AIR HYDRAULIC PUMPS</b>			
700	8-14	1/4"-18NPTF	3/8"-18NPTF

Model Number	Oil Capacity cc	Output Flow Rate (L/min)		Dimensions (mm)					Weight (kg)	
		No Load	Load	A	B	C	D	E		
<b>PUMPS FOR USE WITH SINGLE ACTING CYLINDERS</b>										
PA600	600	1.00	0.15	426	250	178	156	142	6.4	
PA600H	600	1.00	0.15	426	250	178	114	146	5.7	
PA1500	1500	1.07	0.18	267	126	185	131	136	8.2	
PA1500A	1500	1.07	0.18	267	126	185	131	136	8.2	
PA2000	2000	1.00	0.15	294	149	207	157	152	9.1	
PA3801	3800	1.00	0.15	321	129	187	133	187	12.3	
PA7550	7550	1.00	0.15	321	153	211	156	214	17.4	
PA1500L	1500	0.90	0.16	279	160	204	130	136	8.8	
PA3801L	3800	0.90	0.16	321	163	207	132	187	13.8	
<b>PUMPS FOR USE WITH DOUBLE ACTING CYLINDERS</b>										
PA1500M	1500	1.07	0.15	267	127	202	135	136	8.7	
PA3801M	3800	1.00	0.18	321	129	205	138	187	13.5	

### PA600 & PA600H

- Pump can work in any position.
- Mounting plate allows the pump to be securely fastened.
- Hydraulic Port swivels for easy connection.



PA600

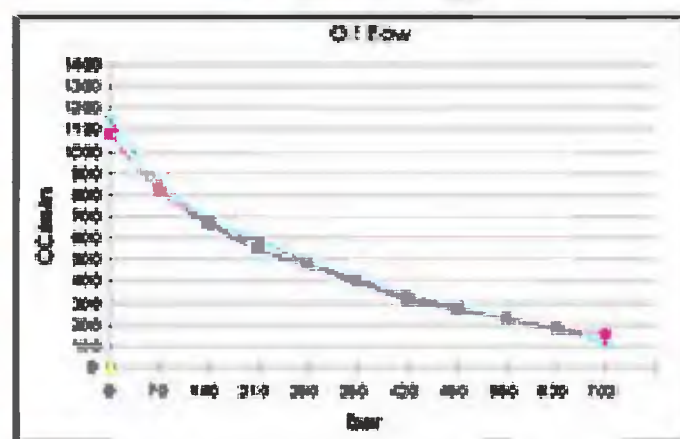

PA600H: With Hand Operation. PA1500L: With Remote Control. PA1500M & PA3801M: With 4-Way Tandem Center Manual Valve.

Valve Operation	Valve Type	Use with Cylinder	Hydraulic Symbol	Schematic Flow path	Weight (kg)
Manual	4-way, Tandem Center	Double Acting			1.8

## Rotary Air Hydraulic Pumps

- Two speed operation for fast and improved productivity.
- Internal relief valve for overload protection.

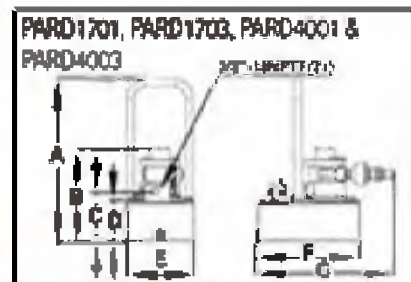
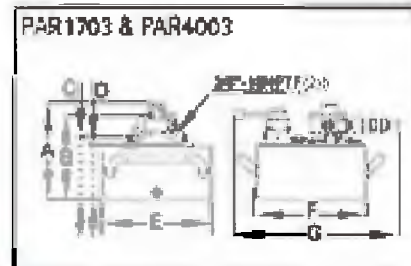
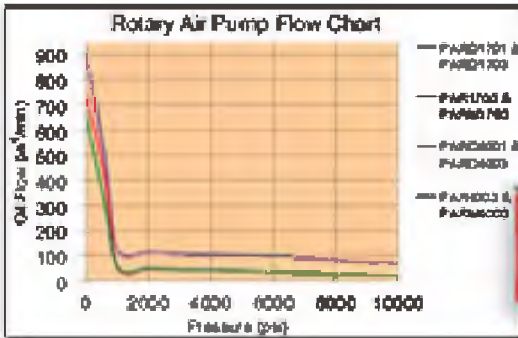

PAR4001

Model Number	Motor Size		Usable Oil Capacity (Liter)	Pressure Rating		Oil Output Flow Rate		Valve Type	Valve Function	Dynamic Air Pressure Range (Bar)
	(kW)	(hp)		First Stage (bar)	Second Stage (bar)	First Stage (L/min)	Second Stage (L/min)			
<b>Used with SINGLE ACTING CYLINDER</b>										
PAR1701	1.3	1.7	3.8	48	700	4.36	0.37	Auto Dump	*Advance/Return	7
PAR1703			11.4							
PAR4001	3	4	3.8	55	700	7.63	1.16			
PAR4003			11.4							
<b>Used with DOUBLE ACTING CYLINDER</b>										
PAR1703	1.3	1.7	11.4	48	700	5.47	0.37	Manual	*Advance/	7
PAR4003	3	4	11.4	55	700	8.39	1.16	PW4	Hold/Return	

Model Number	Air Consumption (L/min)	Sound Level (dBA)	Dimensions							Weight (kg)
			A (mm)	B (mm)	C (mm)	D (mm)	E (mm)	F (mm)	G (mm)	
<b>Used with SINGLE ACTING CYLINDER</b>										
PAR1701	1246	93	485	238	147	120	205	313	404	16.5
PAR1703	1246	93	-	304	212	185	305	313	456	21
PAR4001	2690	100	485	278	147	120	205	313	415	20
PAR4003	2690	100	-	344	212	185	305	313	467	22
<b>Used with DOUBLE ACTING CYLINDER</b>										
PAR1703	1246	93	303	267	209	185	305	313	459	20.5
PAR4003	2690	100	344	267	209	185	305	313	470	26.9

Valve Operation	Valve Type	Use with Cylinder	Hydraulic Symbol	Schematic Flow Path for Dump Valve				Weight (kg)
Manual	Auto Dump	Single Acting						1.0

Valve Operation	Valve Type	Use with Cylinder	Model Number	Hydraulic Symbol	Schematic Flow path			Weight (kg)
Manual	4-way, Tandem Center	Double Acting	PW4					1.8

## Electric Pumps

- Quiet operation meets OSHA regulations (80dBA).
- 2 Speed operation.
- Full load starting capacities.
- Large easy-carrying handles.
- Internal filter prevents contamination from damaging pump.
- Rugged durable design meets the demands of industrial application.
- Precision components to minimize wear and improve overall dependability.
- Available in 3-way or 4-way configuration.
- Ideal for on site construction as well as maintenance.
- In combination with PWSC several manual operated Bieri components can be used on PE pumps.

**Electrical Pumps**  
will be delivered  
without hydraulic  
oil inside.



PE3015  
Custom Made

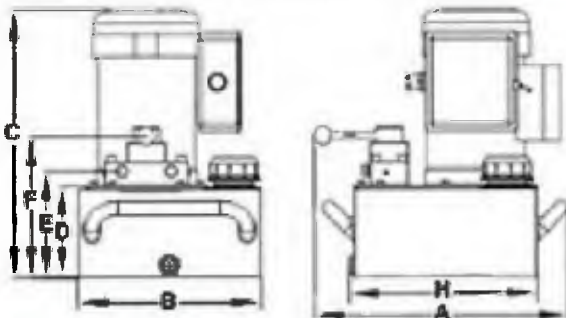

PEW03  
Remote Control



Model Number	Valve Type	Valve Function	Motor Voltage (volts)	Sound Level (dBA)
<b>230 Volt</b>				
PE0501	Manual	4-way 3-position	230	80
PE1002				
PE1503				
PE3005				
PE3015				
<b>380 Volt</b>				
PE3006	Manual	4-way 3-position	380	80

PE0501

Model Number	Motor Size (kW)	Usable Oil Capacity (Liter)	Pressure Rating (bar)		Oil Output Flow Rate (Liter)		Current Draw (Amp)	A (mm)	B (mm)	C (mm)	D (mm)	E (mm)	F (mm)	H (mm)	W.L for PE (kg)
			1 <sup>st</sup> Stage	2 <sup>nd</sup> Stage	1 <sup>st</sup> Stage	2 <sup>nd</sup> Stage									
<b>230 Volt</b>															
PE0501	0.37	3.8	25	700	4.2	0.22	4.5	379	261	485	120	144	203	314	28.5
PE1002	0.75	7.6	48	700	4.2	0.46	6	421	305	454	152	176	234	314	33.0
PE1503	1.12	11.4	48	700	5.1	0.89	8.5	421	305	502	185	209	287	314	41.5
PE3005	2.24	19.4	48	700	6.3	1.22	17	421	305	674	312	336	394	314	47.0
PE3015	2.24	56.0	48	700	6.3	1.22	17	530	570	911	570	593	652	-	76.0
<b>380 Volt</b>															
PE3006	2.24	22.7	48	700	6.3	1.33	4.5	524	376	583	224	247	307	436	62.0

Valve Operation	Valve Type	Use with Cylinder	Model Number	Hydraulic Symbol	Schematic Flow path			Weight (kg)
Manual	4-way, Tandem Center	Double Acting	PW4					1.8

ELECTRIC PUMPS (with solenoid valve)

## Electric Pumps (with Bieri Solenoid Valve)

- Quiet operation meets OSHA regulations (80dBA).
- Ideal for applications where a remote control is required.
- 2 speed operation.
- Full load starting capabilities.
- Internal filter prevents contamination from damaging pump.
- 3.65 meter hand-held remote control, controls the solenoid valve.
- Several Bieri components (flow/pressure control) etc. usable in combination with PES pumps.

**Electric Pumps**  
Will be delivered without Hydraulic Oil

**Solenoid Valve**  
Also possible with 3-way/3-position valve



Model Number	Use with Cylinder	Motor Size (hp)	Usable Oil Capacity (liter)	Pressure Rating		Oil Output Flow Rate		Valve Type	Valve Function	Current Draw (Amp)	Motor Voltage (Volts)	Weight (kg)
				First Stage (bar)	Second Stage (bar)	First Stage (l/min)	Second Stage (l/min)					
PES0501	Double Acting	0.5	3.8	25	700	3.938	0.246	4-way 3-position	Advanced Hold/ Return	4.5	230	33.5
PES1002		1	7.6	48	700	4.182	0.492			6		38.5
PES1503		1.5	11.4	48	700	6.314	0.82			8.5		46.6
PES3006		3	18.9	48	700	7.052	1.476			17		52.5

Model Number	Dimensions (mm)						
	A (mm)	B (mm)	C (mm)	D (mm)	E (mm)	F (mm)	H (mm)
PES0501	386.1	310	485.2	120.0	143.5	277.9	315.9
PES1002	407.2	321	454.1	151.8	175.3	309.7	313.5
PES1503	407.2	321	502.3	184.8	208.3	342.7	313.5
PES3006	407.2	321	654.1	311.8	335.3	469.7	313.5





# Combustion Engine Pumps

- Gas pump can provide 10,000 psi / 700 Bar hydraulic force at remote locations.
- Industrial grade 5.5 HP Petrol or Diesel engine.
- Manual control valve for use with single or double acting cylinders or tools.
- Two speed operation.
- Pump features a sturdy protective roll cage for use in the toughest environments.
- In combination with PWSC several manual operated Bieri components can be used on PG or PD pumps.

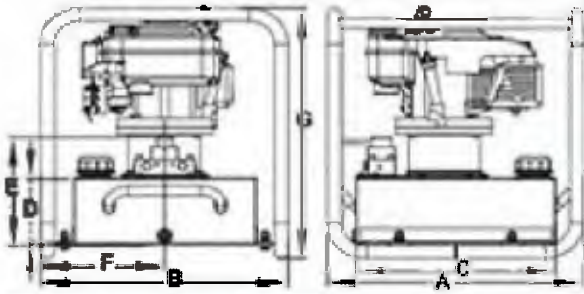

**Gasoline Pump:**  
*Will be delivered without hydraulic oil inside.  
 No Stock item, only on special request!*

COMBUSTION ENGINE PUMPS

Model Number	Motor Size (kW)	Valve Type	Pressure Rating (bar)		Oil Output Flow Rate (L/min)		Valve Function	Rotation Speed (rpm)	Sound Level (dBA)	A (mm)	B (mm)	C (mm)	D (mm)	E (mm)	F (mm)	G (mm)	Weight (kg)
			1 <sup>st</sup> Stage	2 <sup>nd</sup> Stage	1 <sup>st</sup> Stage	2 <sup>nd</sup> Stage											
<b>Usable Oil Capacity: 19 Liter</b>																	
PG5505	4.1	Manual	48	700	11.68	1.64	4-way 3-position	3600	93	592	572	460	159	273	283	620	55
PD3505	4.1	Manual	48	700	11.68	1.64	4-way 3-position	3600	93	592	572	460	159	273	283	670	73

## Pumps / Cylinders Operation and Speed Charts

Model Number	Number of stroke per cm of Cylinder Plunger Travel															
	5 ton		10 ton		15 ton		25 ton		30 ton		50 ton		75 ton		95 ton	
	No Load	Load	No Load	Load	No Load	Load	No Load	Load	No Load	Load	No Load	Load	No Load	Load	No Load	Load
<b>Power Stroke (Based on 7 bar air pressure)</b>																
PA215	3	3	6	6	9	9	14	14	17	17	29	29	42	42	54	54
PA36	2	6	6	18	7	26	11	41	13	52	22	87	32	127	41	162
PA100	1	3	2	7	2	9	3	16	4	19	6	31	8	46	11	66
PA20/PA20M	1	3	2	7	2	9	3	16	4	19	6	31	8	45	10	66
<b>Power Stroke Act (Based on 7 bar air pressure)</b>																
PA600	0.4	2.6	0.9	5.8	1.2	8.1	2.0	13.3	2.5	16.8	4.2	28.3	6.2	41.6	8.0	53.1
PA500	0.4	2.1	0.9	4.8	1.2	6.8	2.0	11.1	2.5	14.0	4.2	23.6	6.2	34.6	8.0	44.2
PA1600	0.4	2.6	0.9	5.8	1.2	8.1	2.0	13.3	2.5	16.8	4.2	28.3	6.2	41.6	8.0	53.1
PA2000	0.4	2.6	0.8	5.8	1.1	8.1	1.9	13.3	2.3	16.8	4.0	28.3	5.8	41.6	7.4	53.1
PA3501	0.4	2.6	0.8	5.8	1.1	8.1	1.9	13.3	2.3	16.8	4.0	28.3	5.8	41.6	7.4	53.1
PA1500L & PA3501L	0.4	2.3	1.0	5.4	1.4	7.6	2.2	12.6	2.8	15.7	4.7	26.6	6.0	39.0	8.8	46.3
<b>Power Stroke (Based on 10 bar air pressure)</b>																
PE2000L	0.1	1.6	0.2	3.5	0.3	4.9	0.5	8.0	0.6	10.1	1.0	17.0	1.8	24.9	1.9	31.8
PE3501	0.1	1.5	0.2	3.3	0.2	4.6	0.4	7.6	0.5	9.8	0.9	16.2	1.3	23.8	1.8	30.4
PE3100	0.1	0.7	0.2	1.7	0.2	2.4	0.4	3.9	0.5	4.9	0.9	8.2	1.3	12.1	1.8	16.4
PE3150	0.1	0.6	0.1	1.0	0.2	1.6	0.3	2.4	0.4	3.0	0.7	5.1	1.0	7.5	1.2	9.6
PE3300S	0.05	0.2	0.1	0.8	0.2	0.8	0.3	1.3	0.3	1.8	0.5	2.7	0.8	4.0	1.0	5.1
PE2001	0.10	1.6	0.2	3.5	0.3	5.0	0.5	8.1	0.6	10.2	1.1	17.3	1.6	25.0	2.0	32.4
PE1600	0.08	0.8	0.2	1.8	0.3	2.5	0.5	4.0	0.6	5.1	1.0	8.6	1.5	12.7	1.9	16.2
PE1503	0.08	0.5	0.1	1.1	0.2	1.5	0.3	2.4	0.4	3.1	0.7	5.2	1.0	7.6	1.3	9.7
PE3005	0.05	0.3	0.1	0.6	0.2	0.8	0.3	1.3	0.4	1.7	0.6	2.9	0.9	4.2	1.1	6.4
<b>Power Stroke (Based on 7 bar air pressure)</b>																
PAR017--	0.04	1.0	0.1	2.4	0.1	3.3	0.2	5.4	0.3	6.8	0.5	11.5	0.7	16.8	0.9	21.5
PAR040--	0.03	0.3	0.1	0.8	0.1	1.1	0.1	1.7	0.2	2.2	0.3	3.7	0.4	5.4	0.5	6.9
PAR17--	0.04	1.0	0.1	2.4	0.1	3.3	0.2	5.4	0.3	6.8	0.4	11.5	0.6	16.8	0.8	21.5
PAR40--	0.03	0.3	0.1	0.8	0.1	1.1	0.1	1.7	0.2	2.2	0.3	3.7	0.4	5.4	0.5	6.9
<b>Power Stroke (Based on 10 bar air pressure)</b>																
PG5505/PD3505	0.03	0.2	0.1	0.5	0.1	0.8	0.2	1.2	0.2	1.6	0.4	2.7	0.5	3.9	0.7	6.0

## Mini Jacks

- Low Profile mini jack.
- Pocket size and light weight.
- Convenient for storage.



### Mini Jacks

Model Number	Capacity Height (Ton)	Capacity Height (kN)	Min. Lifting (mm)	Max. (L x W) (mm)	Hydraulic (mm)	Base Size (mm)	Weight (kg)
J11050	5	50	70	90	38	105 x 120	2.1
J11086	5	50	86	124	38	105 x 120	2.4
J11100	10	100	121	159	41	124 x 110	5.7
J11200	20	200	130	171	41	137 x 121	7.6

## Toe Jacks

- Heat treated and chrome plated medium-carbon steel cylinder.
- Chrome plated ram optimizes the performance and insures a longer seal life.
- U.S. Patented by-pass device protects hydraulic system from overtravelling damage.

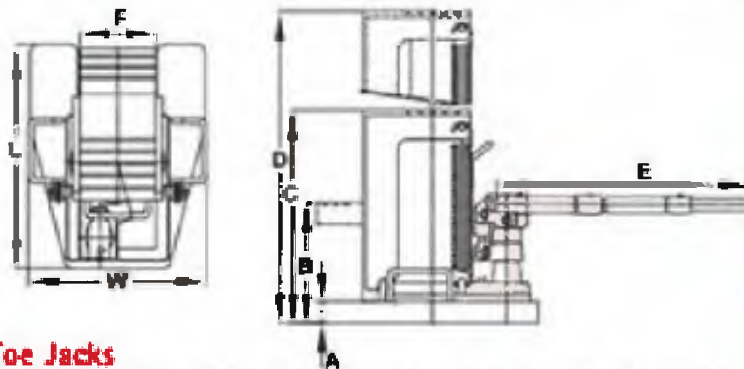

### Toe Jacks

Model Number	Capacity (Ton)	Capacity (kN)	A (mm)	B (mm)	C (mm)	D (mm)	E (mm)	F (mm)	L (mm)	W (mm)	Weight (kg)
J13080	3	30	16	146	230	360	600	88	215	190	17.8
J13120	6	60	22	152	267	397	600	80	280	190	27.2
J13200	10	100	28	158	280	410	600	100	295	234	39.5
J13300	15	147	28	168	332	472	972	100	316	272	54.3

## Spreaders

- Multi-purpose applications: to spread, lift, level machinery or collision repair.
- Designed to work in confined working areas.
- Jaws close automatically with the return spring after the pressure is released.



### Spreaders

Model Number	Capacity (Ton)	Capacity (kN)	Cylinder Effective Area (mm <sup>2</sup> )	Oil Capacity (cc)	Dimensional/ Range (mm)	Weight (kg)
SR05	0.5	4.9	7.9	9.5	90 192 13 52 60	1.9
SR10	1	9.8	7.0	14.1	99 167 12 55 56	2.2
SR100T	10	98	N/A	N/A	N/A 235 7/17 50 37/47	3

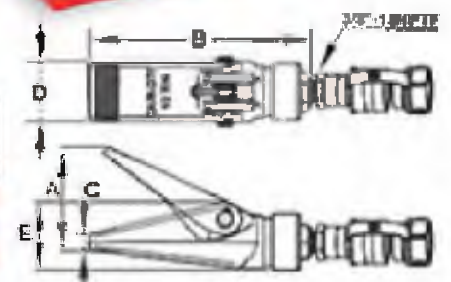

## Puller 2 Legs

APL1205



Art. Number	Cylinder (Optional)	Capacity Ton	A	B (min.)	B (max.)	W (min.)	W (max.)	C	KG
			(mm)	(mm)	(mm)	(mm)	(mm)	(mm)	
AP1205	H0503	5	160	60	200	175	270	260	8.5
APL1205	H0503	5	220	60	200	175	270	260	9.0

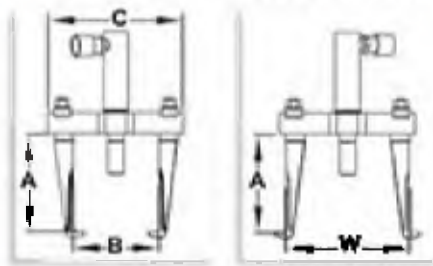

AP2205



Art. Number	Cylinder (Optional)	Capacity Ton	A	B (min.)	B (max.)	KG
			(mm)	(mm)	(mm)	
AP2205	H0803	5	190	82	250	7.8

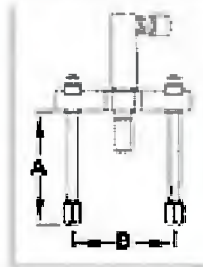

APS1204  
APS1206

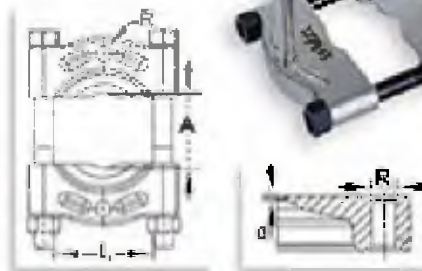

Art. Number	A (min.)	A (max.)	L	R	e	KG
	(mm)	(mm)	(mm)	(mm)	(mm)	
APS1204	10	110	110	5/8"	2.5	2.8
APS1206	12	134	155	5/8"	2.0	5.7

## Puller 2/3 Legs

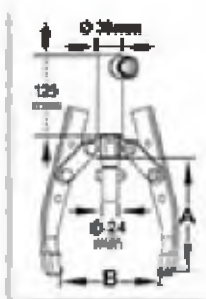

AP1305



Art. Number	Cylinder (Optional)	Capacity Ton	A	B (max.)	KG
			(mm)	(mm)	
AP1305	H0503	5	225	240	7.8

## Puller Kit

### Puller Kits Existing of:

- ◆ 2/3 Leg Puller
- ◆ 2 Leg Puller
- ◆ Extensions for 2 Leg Puller
- ◆ Splitter

Puller Kit	Capacity Ton	2/3-Leg Puller	2-Leg Puller	Extender Set	Splitter	KG
APK1005	5	AP1305	APL1205	APE1108 + APE1118	APS1204	18



## Hydraulic Set - Single Acting Cylinder

### Hydraulic Set Existing of:

- ◆ Handpump P350
- ◆ Cylinder H0503
- ◆ Gauge Et Gauge Adaptor
- ◆ Hose
- ◆ Fitting Et Coupler



Hydraulic Set	Capacity Ton	Handpump	Fitting	Gauge + Adaptor	Hose	Coupler	Cylinder	KG
APH0503	5	P350	CA3814	GBW1460 + CF3814	CS3814-2	CH38-M	H0503	5

## Puller (3 and 2/3 Legs)



APC2300  
Self-Centered  
3 or 2/3 Leg  
Pullers

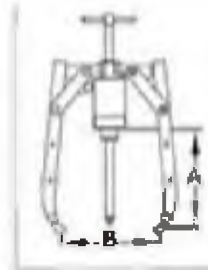
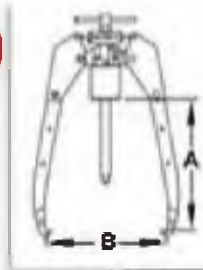

AP2300  
3 or 2/3 Leg  
Pullers



Art. Number	KG	Cylinder (Optional)	Capacity Ton	Legs	A (mm)	B (min.) (mm)	B (max.) (mm)	Art. Number	KG
APC2310	15	HC1202	10	2/3	296	50	350	AP2310	9
APC2320	33	HC2002T	20	3	320	70	480	AP2320	23
APC2330	57	HC3002T	30	3	407	90	580	AP2330	40
APC2360	134	HC6003T	60	3	750	120	1080	AP2360	87

## Puller Kit

### Puller Kits Existing of:

- ◆ 2 Leg Puller
- ◆ Extension Legs
- ◆ Splitter
- ◆ Internal Puller
- ◆ Joining Nuts
- ◆ Point Protection
- ◆ 2/3 Leg Puller (Optional)



2 Leg  
Pull Device



Extension  
Legs



Joining Nuts



Point Protection



Splitter



Internal  
Puller

Puller Kit	Incl. 3-Leg Puller	Incl. Self-Centered 3-Leg Puller	Capacity Ton
APK1010	(2/3-Leg) APK1110	(2/3-Leg) APK1210	10
APK1020	(3-Leg) APK1120	(3-Leg) APK1220	20
APK1030	(3-Leg) APK1130	(3-Leg) APK1230	30
APK1060	(3-Leg) APK1160	(3-Leg) APK1260	60
APK1061	(3-Leg) APK1161	(3-Leg) APK1261	60

### Application:

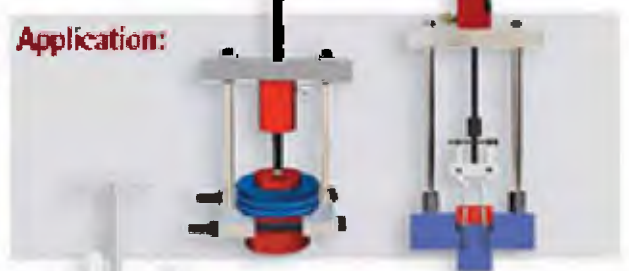

## Hydraulic Set

### Hydraulic Set Existing of:

- ◆ Handpump
- ◆ Hose
- ◆ Hollow Cylinder
- ◆ Fitting & Coupler
- ◆ Gauge and Gauge Adaptor



Hydraulic Set	Capacity Ton	Handpump	Fitting	Gauge + Adaptor	Hose	Coupler	Hollow Cylinder	Saddle	KG
APHC1202	10	P350	Incl.	GBW1460 + CF3814	C3814-2	CRZ14-M	HC1202	-	10
APHC2002	20	P350	Incl.	GBW1460 + CF3814	C3814-2	CH38-M	HC2002T	APS20	15
APHC3002	30	P350	Incl.	GBW1460 + CF3814	C3814-2	CH38-M	HC3002T	APS30	18
APHC6003	60	P1000	Incl.	GBW1460 + CF3814	C3814-2	CH38-M	HC6003T	APS60	46

PULLERS FOR HOLLOW CYLINDERS

**PULLERS FOR HOLLOW CYLINDERS**

Art. Number	Capacity TON								Point Protection	KG
APK1010	10			AP2210	APE1120 + APE1146	APS1204	API1210	AJN05	APP10	35
APK1020	20			AP2220	APE1220 + APE1252	APS1206	API1220	AJN10	APP20	60
APK1030	30			AP2230	APE1333 + APE1358	APS1210	API1230	AJN30	APP30	120
APK1060	60			AP2250	APE1550 + APE1582	APS1210D	API1250	AJN50	APP30	215
APK1061	60			AP2250	APE1550 + APE1582	APS1212	API1250	AJN50	APP30	230
APK1110	10		AP2310 (2/3 Leg)	AP2210	APE1120 + APE1146	APS1204	API1210	AJN05	APP10	44
APK1120	20		AP2320 (3 Leg)	AP2220	APE1220 + APE1252	APS1206	API1220	AJN10	APP20	83
APK1130	30		AP2330 (3 Leg)	AP2230	APE1333 + APE1358	APS1210	API1230	AJN30	APP30	160
APK1160	60		AP2360 (3 Leg)	AP2250	APE1550 + APE1582	APS1210D	API1250	AJN50	APP30	302
APK1161	60		AP2360 (3 Leg)	AP2250	APE1550 + APE1582	APS1212	API1250	AJN50	APP30	317
APK1210	10	APC2310 (2/3 Leg)		AP2210	APE1120 + APE1146	APS1204	API1210	AJN05	APP10	50
APK1220	20	APC2320 (3 Leg)		AP2220	APE1220 + APE1252	APS1206	API1220	AJN10	APP20	93
APK1230	30	APC2330 (3 Leg)		AP2230	APE1333 + APE1358	APS1210	API1230	AJN30	APP30	177
APK1260	60	APC2360 (3 Leg)		AP2250	APE1550 + APE1582	APS1210D	API1250	AJN50	APP30	349
APK1261	60	APC2360 (3 Leg)		AP2250	APE1550 + APE1582	APS1212	API1250	AJN50	APP30	364



Art. Number	Capacity Ton	A (mm)	B (mm)		KG
			(min)	(max)	
AP2310	10	296	50	360	9
AP2320	20	320	70	480	23
AP2330	30	407	90	580	40
AP2360	60	750	120	1060	87



Art. Number	A1 (mm)	A2 (mm)	B (mm)		C	R1	R2	KG
			(min)	(max)				
API1210	115	237	40	145	133	3/4" UNF-16h	5/8"-14h	2.0
API1220	115	237	40	145	133	1" UNF-8h	5/8"-14h	2.4
API1230	150	310	60	240	202	1 1/4" UNF-7h	1"-14h	6.0
API1250	150	310	60	240	202	1 1/8" UNF-5.5h	1"-14h	6.4

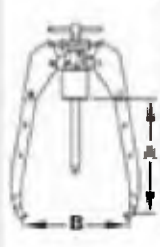

Art. Number	Capacity Ton	A (mm)	B (mm)		KG
			(min)	(max)	
APC2310	10	296	50	360	15
APC2320	20	320	70	480	33
APC2330	30	407	90	580	57
APC2360	60	750	120	1060	134

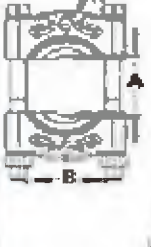

Art. Number	A (mm)		L (mm)	R	o (mm)	KG
	(min)	(max)				
APS1204	10	110	110	5/8"	2.5	2.8
APS1206	12	134	155	5/8"	2	5.7
APS1210	17	250	260	1"	4	28.5
APS1210D	17	250	260	1 1/4"	4	28.5
APS1212	35	300	300	1 1/4"	4.5	43.5



Art. Number	Capacity Ton	A (mm)	B (mm)		C (mm)	KG
			(min)	(max)		
AP2210	10	300	115	260	280	18.5
AP2220	20	265	140	345	370	34.7
AP2230	30	284	180	440	480	56
AP2250	60	447	220	560	615	113.5



Art. Number	L (mm)	M (mm)	Ø D (mm)	R1	R2
APE1220	209	89	25	5/8"-16h	3/4"-16h
APE1333	328	158	32	1"-14h	1"-14h
APE1550	504	292	42	1 1/4"-12h	1 1/4"-12h
APE1146	230	150	16	5/8"-16h	1/2"-20h
APE1252	515	395	25	5/8"-16h	3/4"-16h
APE1582	592	412	32	1"-14h	1"-14h
APE1582	820	608	42	1 1/4"-12h	1 1/4"-12h

## Press

- New series of presses with double speed hydraulic hand pump and single acting ram with return spring.
- All presses are supplied with 2 "V" Arbor Plates and a punch plate.
- With the 50 ton model, a moveable cylinder is included.
- The presses are designed and manufactured as per the latest CE directives.
- A winch for hoisting the working table is included with the presses.



Two "V" Arbor Plates included



Winch to lift working table



Double speed Handpump with Gauge



H-FRAME PRESSES

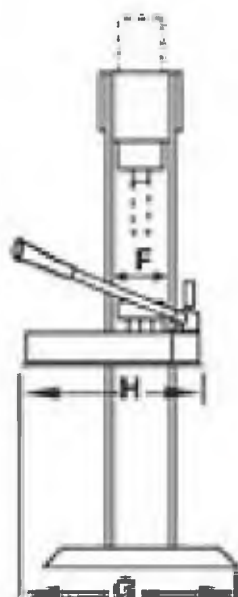
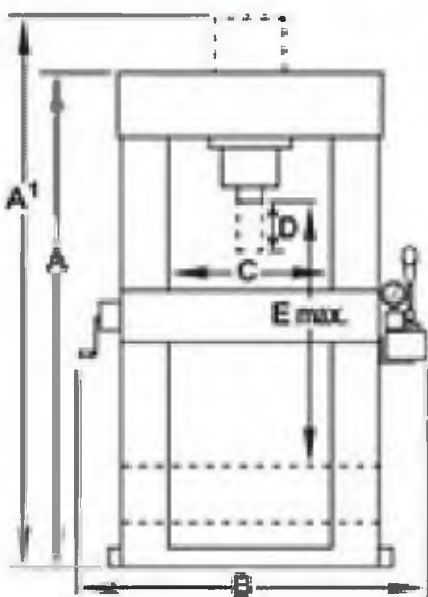

Optional:  
SAP 50 Adapters

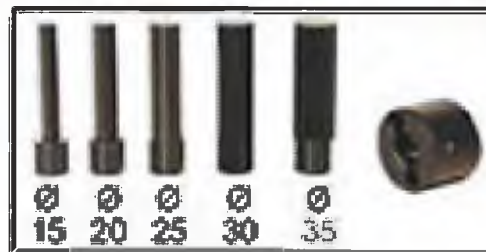

Model Number	Cylinder	Pump	A (mm)	A1 (mm)	B (mm)	C (mm)	D (mm)	E (mm)	F (mm)	G (mm)	H (mm)	Weight (kg)
<b>MANUAL PRESS 50 TON</b>												
SMS5510	H5510	P2301	2000	2080	1360	785	260	1260	180	750	670	412
SMS5513	H5513	P4301	2000	2160	1380	785	337	1260	180	750	670	415
<b>MANUAL PRESS 100 TON</b>												
SMS10010	H10010	P4301	2100	2210	1700	1025	260	1150	270	950	670	1160



## Electrical Press

- New series of electrical presses with double acting cylinder.
- All presses are supplied with 2 "V" Arbor Plates and a punch plate.
- A moveable Ram and winch to hoist the working table is included with the presses.

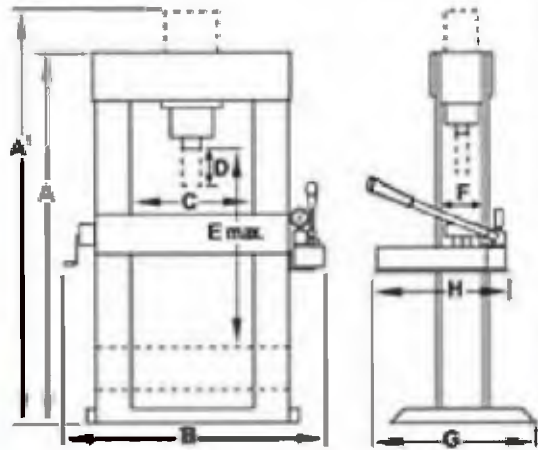

**REMOTE CONTROL OPERATION:**  
Easy and flexible operation by means of the remote control.



SED10013

Model Number	Cylinder	Pump	A (mm)	A1 (mm)	B (mm)	C (mm)	D (mm)	E (mm)	F (mm)	G (mm)	Weight (kg)
<b>ELECTRICAL PRESS WITH REMOTE CONTROL</b>											
SED5513	HD5513	PE0501	2000	2160	1080	785	335	1260	180	750	440
SED10013	HD10013	PE1002	2100	2210	1900	1025	333	1150	270	850	1220

### Operating by: "Two"-hands

- Safe Two-hand operation.
- Flashing warning light - when operating.



SEC10013

Model Number	Cylinder	Pump	A (mm)	A1 (mm)	B (mm)	C (mm)	D (mm)	E (mm)	F (mm)	G (mm)	Weight (kg)
<b>ELECTRICAL PRESS "TWO-HANDS" OPERATION</b>											
SEC5513	HD5513	PE0501	2000	2160	1580	785	336	1260	180	750	445
SEC10013	HD10013	PE1002	2100	2210	1900	1025	333	1150	270	850	1230



H-FRAME PRESSES



# Hydraulic Accesories

## Coupler

Model Number			Dimensions (mm)									Dust Cap(s)
Complete Set	Male Half	Female Half	A*	B	C	D	E	F	G	H	J	
<b>High-Flow Coupler</b>												
CH38	CH38M	CH38F	81.1	72.1	3/8"-18NPTF	1 3/16"-16	28	24	25	19	16	Included
<b>Regular-Flow Coupler</b>												
CR38	CR38M	CR38F	60	55.9	3/8"-18NPTF	15/16"-20	26	24	19	13	13	Included
CRZ14	CRZ14M	CRZ14F	61.5	42.4	1/4"-18NPTF	13/16"-20	24	21	15	10	9	Included

Model Number		Female Half	A*	B	C	D	E	E'	F	G	H	J	Dust Cap(s)
<b>High-Flow Quick-Connection Coupler</b>													
CO38	CO38M	CO38F	104.5	60.5	3/8"-18NPTF	15.6-15	25	27.5	22	24	15.0-15.6	N/A	Included
		COF38F	115.0	71.0									

\* Value A is total length when male and female couplers are connected.



## Hoses

### Hose Exceeds DIN 20022-1 and SAE 100R9 Specifications

- Rubber Bend Restrictors.
- High Working Pressure.
- Optimum Flexibility.
- Light Weight.
- Temperature Range: From -40°C up to +100°C.



Model Number	Length (cm)	I.D. Ø	Hose End Fittings	Operating Pressure (bar)	Bursting Pressure (bar)	Bend Radius (mm)	Oil Volume (cc)	Weight (kg)
<b>Hose 2M</b>								
CS3814-1	100	6.35mm / 1/4"	3/8"-18NPTF	700	2600	100	115	0.45
CS3814-2	200	6.35mm / 1/4"	3/8"-18NPTF	700	2600	100	230	0.70
CS3814-3	300	6.35mm / 1/4"	3/8"-18NPTF	700	2600	100	345	0.95
CS3814-4	400	6.35mm / 1/4"	3/8"-18NPTF	700	2600	100	460	1.20
CS3814-6	600	6.35mm / 1/4"	3/8"-18NPTF	700	2600	100	690	1.70
CS3814-10	1000	6.35mm / 1/4"	3/8"-18NPTF	700	2600	100	1,150	2.70

### Hose Custom Length (Special Order; No Stock Item)

CS38	-	-	3/8"-18NPTF	-	-	-	-	0.20
CS14M	100	6.35mm / 1/4"	-	700	2600	100	115M <sup>1</sup>	0.25

Model Number	Length (cm)	I.D. Ø	Hose End Fittings	Operating Pressure (bar)	Bursting Pressure (bar)	Bend Radius (mm)	Oil Volume (cc)	Weight (kg)
--------------	-------------	--------	-------------------	--------------------------	-------------------------	------------------	-----------------	-------------

<b>Hose 2M</b>								
CS3838-2	200	9.5mm / 3/8"	3/8"-18NPTF	700	2600	150	515	0.60

### Hose Custom Length (Special Order; No Stock Item)

CS38	-	-	3/8"-18NPTF	-	-	-	-	0.20
CS38M	100	9.5mm / 3/8"	-	700	2600	150	257M <sup>1</sup>	0.30



## Pressure Gauge

Model Number	Face Diameter	Fitting	Thread	Pressure Range		Graduation			
						Major Graduation		Minor Graduation	
						(psi)	(bar)	(psi)	(bar)
<b>Wet</b>									
GBW1480	63	Brass	1/4"-18NPTF	0-15,000	0-1000	1000	500	100	20
GBW14100	105	Brass	1/4"-18NPTF	0-15,000	0-1000	1000	500	100	20
GSW1450	63	Stainless Steel	1/4"-18NPTF	0-10,000	0-700	1000	500	100	20



GBW1480

## Fitting / Gauge Adaptor

Model Number	Dimensions (mm)					
	A	B	C	D	E	F
CF3&14	130	35	1/4"-18NPTF	3/8"-18NPTF	3/8"-18NPTF	32

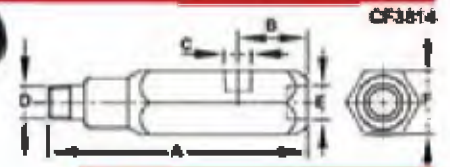

CF3&14

## Manifold

Model Number	Number of Ports	Port Size	Mounting Hole
<b>8-PORT HEXAGON MANIFOLD</b>			
CMH6	6	3/8"-18NPTF	1/4"-20UNC
<b>17.8 cm Long Manifold</b>			
CM7	7	3/8"-18NPTF	1/4"-20UNC
<b>35.6 cm Long Manifold</b>			
CM14	7	3/8"-18NPTF	1/4"-20UNC

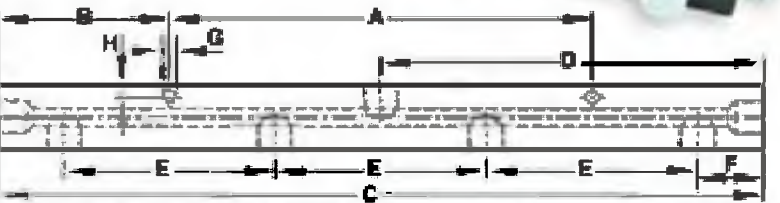
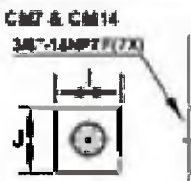
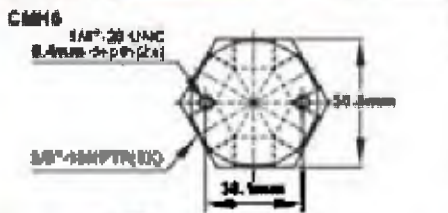

Model Number	A (mm)	B (mm)	C (mm)	D (mm)	E (mm)	F (mm)	G (mm)	H (mm)	I (mm)	J (mm)
CM7	76.2	50.8	177.8	68.9	38.1	31.8	6.4	6.3	31.8	31.8
CM14	203	82.5	368	184	101.5	31.8	6.4	6.4	31.8	31.8

## Manifold - Split Flow

Model Number	Number of Ports	Port Size	Mounting Hole
<b>SPLIT FLOW MANIFOLD</b>			
MFC2	2	3/8"-18NPTF	1/4"-20UNC
<b>SPLIT FLOW MANIFOLD</b>			
MFC4	4	3/8"-18NPTF	1/4"-20UNC

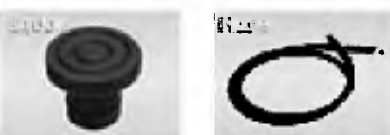
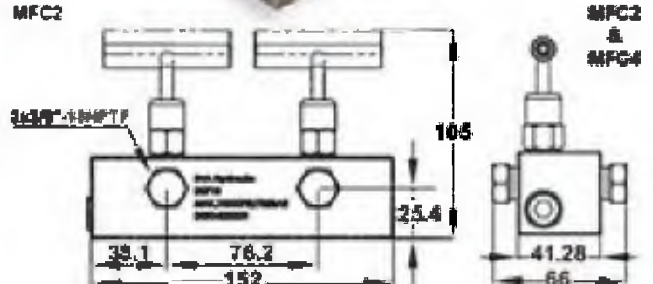
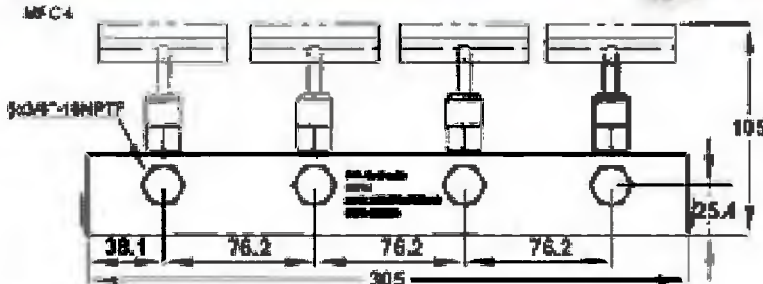

ACCESSORIES: MANIFOLDS / GAUGES

## Flow Control Valve

**CVN1 / CVN3**

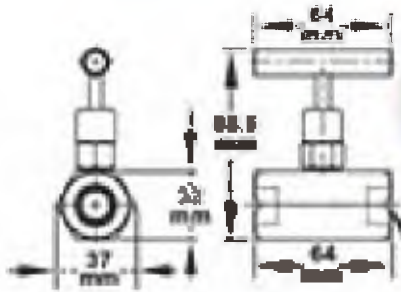

CVN1: 1/4"-18NPTF  
CVN3: 3/8"-18NPTF

**CVC3**



**CVP3**

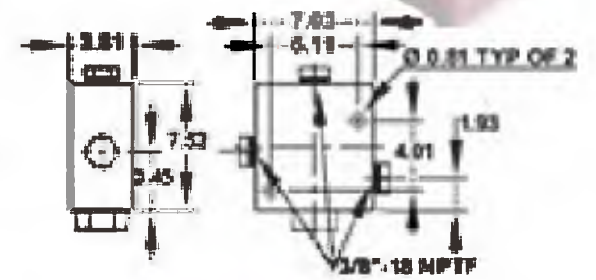

**CVR3  
CVR3H**

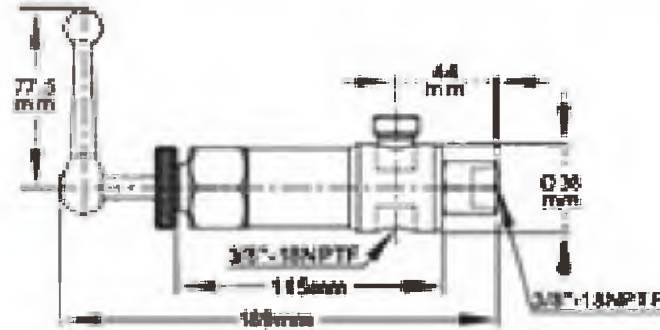

**CVS1**



Model Number	Ports	Application	Hydraulic Symbol
<b>NEEDLE VALVE</b>			
CVN1	1/4"-18NPTF	Controls cylinder speed and acts as temporary shut-off valve for load holding.	
CVN3	3/8"-18NPTF		
<b>CHECK VALVE</b>			
CVC3	3/8"-18NPTF	Allows flow in one direction only.	
<b>PILOT OPERATED CHECK VALVE</b>			
CVP3	3/8"-18NPTF	Pilot operated Check Valve.	
<b>PRESSURE RELIEF VALVE</b>			
CVR3	3/8"-18NPTF	Controls pressure developed by the pump in hydraulic loop. By-pass occurs when pre-set pressure is reached. Turn clockwise to increase pressure counter clockwise to decrease.	
CVR3H	3/8"-18NPTF	Same as CVR3, but return line hose / 1 meter length is included.	
<b>PRESSURE ACTUATOR PE PUMP</b>			
CVS1	1/4"-18NPTF	Adjustable control for the PE (only) pumps dispensing pressure. Step less control range: 100 to 700 bar. On/off pressure differential 50/100 bar. Pressure actuator is supplied with connector similar as the remote control. So "plug and play" by the remote control connection.	

## Pump Mounted Valves



**PW3**



**PW3XL & PW4XL**

Valve Operation	Valve Type	Use with Cylinder	Model Number	Hydraulic Symbol	Schematics per port	Weight (kg)
Manual	3-way, Tandem Center	Single Acting	PW3			1.8
	3-way, Tandem Center		PW3			1.8
	4-way, Tandem Center	Double Acting	PW4			1.8
	3-way, 3 position, Tandem Center, Locking	Single Acting	PW3XL			2.7
	4-way, 3-position, Tandem Center, Locking	Double Acting	PW4XL			2.7

## Pump Mounted Manifold Block

CMR2



## Remote Mounted Valves

PR33

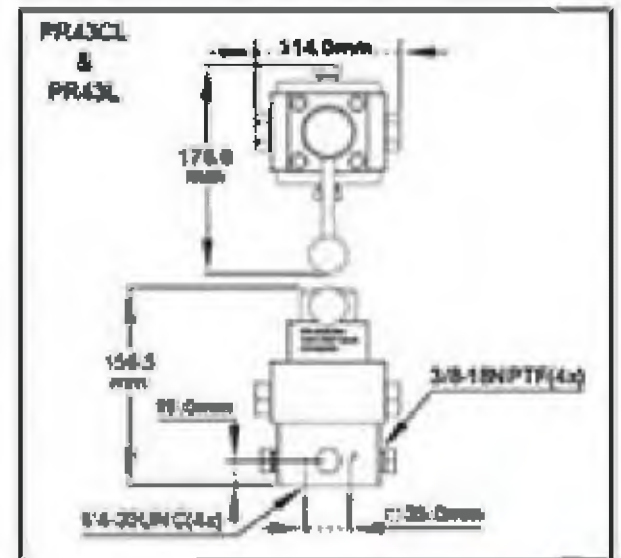
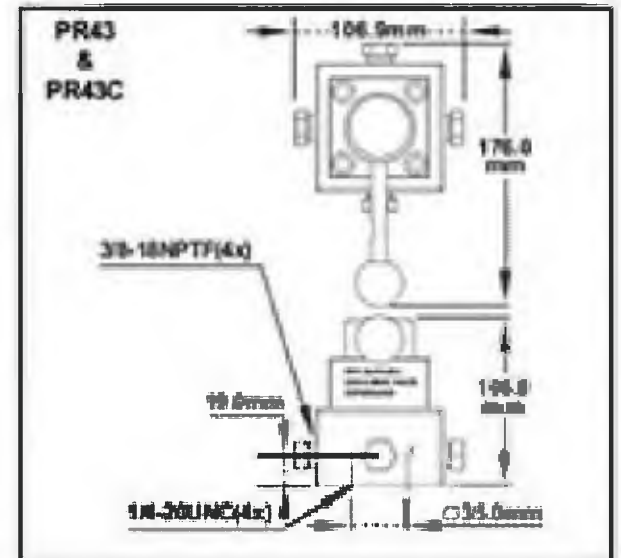
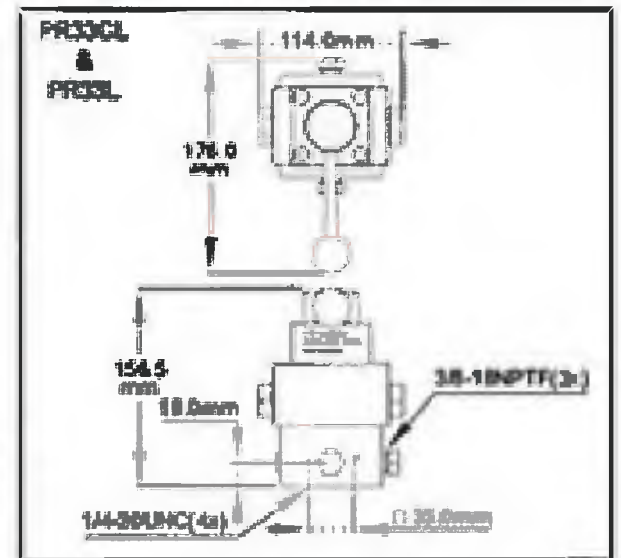
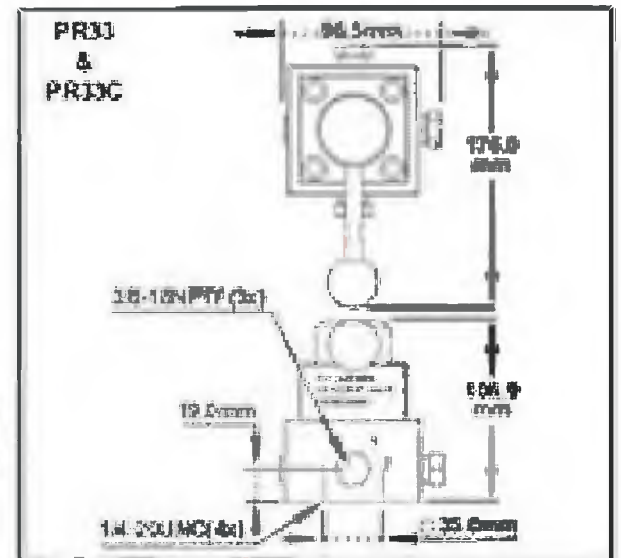

Valve Operation	Valve Type	Use With Cylinder	Model Number	Hydraulic Symbol	Operational Flow path			Weight (kg)
Manual	3-way, 3 position, Tandem center	Single Acting	PR33					1.6
	3-way, 3 position, Closed center		PR33C					1.6
	3-way, 3 position, Tandem center, Locking		PR33L					2.6
	3-way, 3 position, Closed center, Locking		PR33CL					2.6
	4-Way, 3 position, Tandem center	Double Acting	PR43					1.6
	4-Way, 3 position, Closed center		PR43C					1.6
	4-Way, 3 position, Tandem center, Locking		PR43L					2.6
	4-way, 3 position, Closed center, Locking		PR43CL					2.6



ACCESSORIES: REMOTE VALVES

## Cylinder Accessories

### Saddle

Model Number	Saddle Type	For use with Cylinder Capacity Ton	Dimension (mm)				
			A	B	C	D	
SD05	Grooved	5	25	6	17	20	
SD10		10	35	6	22	27	
SD15		15	38	7	22	30	
SD25		25	50	7	36	29	
SDT05	Tilt	5	25	17	17	31	
SDT10		10	35	16	22	37	
SDT15		15	38	19	22	40	
SDT25		25	50	19	36	40	
SDT55		50/75/100	70	33	70	33	
HTD10	Threaded	10	1 1/4"-11	1/2NPTF	26	1"-8UNC	45

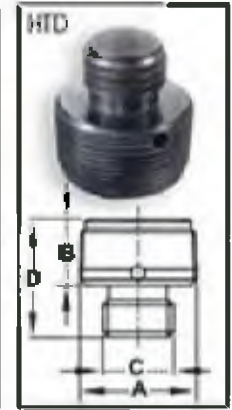

### Clevis

Model Number	Clevis Type	For use with Cylinder Capacity Ton	Dimension (mm)											
			A	B	C	D	E	F	G	H	M	X	Y	Z
CEP05	Plunger	5	3/4"-16UNF	29	57	18	18	14	-	25.5	-	-	-	-
CEP10		10 + 15	1"-8UNC	43	84	22	19	25	-	39.7	-	-	-	-
CEP25		25	1 1/2"-16	57	97	32	22	38	-	42.8	-	-	-	-
CEB05		Base	5	38.6	44	54	16	29	6.5	-	39.0	26	6.4	12.7
CEB10	10		58.0	63	73	22	43	8.2	-	47.6	38	6.4	12.7	-
CEB15	15		70.4	76	73	22	43	9.7	-	47.6	48	6.4	12.7	-
CEB25	25		86.2	95	86	32	57	14.3	-	54.0	58	6.4	12.7	-
CP10*	Plunger & Base	only HP1006	M30x2	75	160	30	95	35	65	128	-	-	-	27

\* 2-pc set with an adaptor

CP10-Clevis Plunger & Base

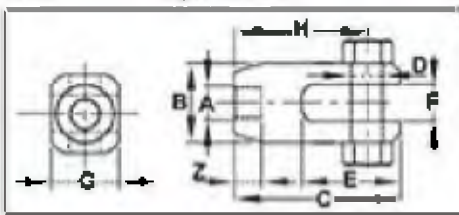

### CEB 15-Base

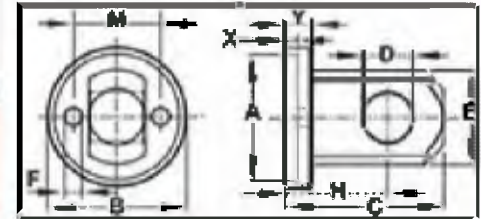

### CEP 15-Plunger

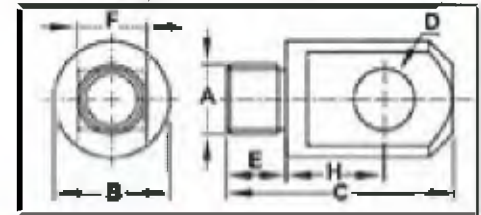

### Hydraulic Oil

Model Number	Volume (l)	Oil Type	Viscosity	For Pump
HV685	5	Hydro HV68	68	Electric



### Base

CB10



Model Number	For use with Cylinder Capacity Ton	Dimension (mm)			
		A	B	C	D
CB05	5	8	118	200	39
CB10	10	10	120	230	58
CB15	15	12	122	254	70
CB25	25	16	126	280	87

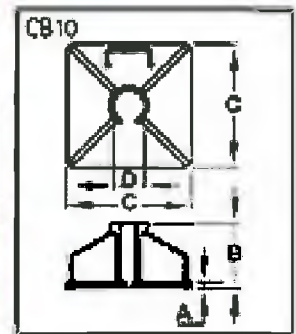

ACCESSORIES: SADDLES / CLEVIS / OIL / BASE

## Fittings

Model Number	Description	Picture	Drawing	Dimensions			
				A (mm)	B (mm)	C	D
CA3814	Adaptor			35	23	Male: 1/4"-18NPTF	Female: 3/8"-18NPTF
CB1438	Adaptor			22	17	Male: 3/8"-18NPTF	Female: 1/4"-18NPTF
FT101	2-way 90° Connector			46	26	Male: 3/8"-18NPTF	Female: 3/8"-18NPTF
FT102	Coupling			30	26	Female: 1/4"-18NPTF	Female: 3/8"-18NPTF
FT112	Coupling			48	29	Female: 1/2"-14NPTF	Female: 3/8"-18NPTF
FT103	Coupling			30	26	Female: 3/8"-18NPTF	Female: 3/8"-18NPTF
FT104	Male Connector			38	17	Male: 1/4"-18NPTF	Male: 1/4"-18NPTF
FT114	Male Connector			38	19	Male: 3/8"-18NPTF	Male: 3/8"-18NPTF
FT105	4-Way Connector			45	26	Female: 3/8"-18NPTF	Female: 3/8"-18NPTF
FT106	3-Way Connector			45	26	Female: 3/8"-18NPTF	Female: 3/8"-18NPTF
FT107	2-Way 90° Connector			35.5	26	Female: 3/8"-18NPTF	Female: 3/8"-18NPTF
FT108	Adaptor			43	29	Male: 3/8"-18NPTF	Female: 1/2"-14NPTF
FT118	Adaptor			43	29	Male: 1/4"-18NPTF	Female: 1/2"-14NPTF

## Confidence Built on Quality

### ISO 9001

BVA products are manufactured through an International Quality Assurance System, ISO 9001/9002, which involves consistent observation of administration, management, manufacturing and production

Products comply with the following industry standards

### SAE 100

BVA hydraulic hoses comply with the Material Handling Institute's specification of minimum life cycles and minimum burst pressure rating.

control. Under this system, the related operations are monitored on all aspects of the production of BVA products from the purchase order, the assembly line, to shipping the order from the distribution center.

### ANSI B30.1

The cylinders comply with load testing requirements and/or the safety factor for material yield strength, whilst functioning properly and without oil leakage.

### ANSI B40.1

Under ANSI standards, BVA pressure gauges meet criteria for grade A.

### Cylinder Plunger Speed

• Formula:  $V = A \div Q$

$$\text{Cylinder Plunger Speed (sec/cm)} = \frac{\text{Cylinder effective Area (cm}^2\text{)}}{\text{Oil Output Flow Rate (cm}^3\text{/min)}} \times \frac{60(\text{sec})}{1 (\text{min})}$$

### Force

• Formula:  $F = P \times A$

$$\text{Force (kgs)} = \text{Hydraulic Working Pressure (kg/cm}^2\text{)} \times \text{Cylinder Effective Area (cm}^2\text{)}$$

### Cylinder Oil Capacity

$$\text{Oil Capacity (cm}^3\text{)} = \text{Cylinder Effective Area (cm}^2\text{)} \times \text{Cylinder Stroke (cm)}$$

### Cylinder Effective Area

$$\text{Cylinder Effective Area} = \pi \times \frac{(\text{Cylinder Bore Diameter})^2}{4}$$

Where:  $\pi = 3.14159$

1Kgf=9.81N

1N=1KG-m/sec<sup>2</sup>

KEY TO MEASUREMENTS	
<b>WEIGHT</b>	
1 pound (lb.)	= 0.4536 kg
1 kg	= 2.205 lbs
1 ton (short, US)	= 2000 lbs
1 ton (metric)	= 2205 lbs
<b>VOLUME</b>	
1 in <sup>3</sup>	= 16.387 cm <sup>3</sup>
1 cm <sup>3</sup>	= 0.061 in <sup>3</sup>
1 liter	= 61.02 in <sup>3</sup>
	= 0.264 gal (US)
1 gal (US, liquid)	= 3.785 liter
	= 231 in <sup>3</sup>
	= 3785 cm <sup>3</sup>
<b>OTHER MEASUREMENTS</b>	
1 in	= 25.4 mm
1 mm	= 0.039 in
1 in <sup>2</sup>	= 6.452 cm <sup>2</sup>
1 cm <sup>2</sup>	= 0.155 in <sup>2</sup>
<b>PRESSURE</b>	
1 psi (lb/in <sup>2</sup> )	= 0.069 bar
1 bar	= 14.5 psi
1 kPa	= 0.145 psi
<b>TEMPERATURE</b>	
0°F	= (0°C × 1.8) + 32
0°C	= (0°F - 32) / 1.8

## TWO-YEAR LIMITED WARRANTY FOR BRAND HYDRAULIC EQUIPMENT

For a period of two (2) year from the date of purchase, Shinn Fu Europe B.V. will repair or replace, at its discretion, without charge, any of its products which fails due to defect in material or workmanship, or which fails to conform to any implied warranty not excluded hereby.

Performance of any obligation under this warranty may be obtained by returning the warranted product, freight prepaid, to Shinn Fu Europe B.V., Warranty Service Department, Tussenriemcr 20, 4704 SR Roosendaal, The Netherlands.

Except where such limitations and exclusions are specifically prohibited by applicable law.

(1) THE CONSUMER'S SOLE AND EXCLUSIVE REMEDY SHALL BE THE REPAIR OR REPLACEMENT OF DEFECTIVE PRODUCTS AS DESCRIBED ABOVE, AND SHALL NOT BE LIABLE FOR LOSS WHAT SO EVER, AND

(2) THE DURATION OF ANY AND ALL EXPRESSED AND IMPLIED WARRANTIES, INCLUDING WITHOUT LIMITATION, ANY WARRANTIES OF MERCHANTABILITY AND FITNESS FOR A PARTICULAR PURPOSE, IS LIMITED TO A PERIOD OF TWO (2) YEARS FROM THE DATE OF PURCHASE.

**Das komplette Leistungsspektrum:**



Dieser Bereich umfasst im wesentlichen das Engineering von Neuanlagen für die Bereiche Hydraulik mit zugehöriger Steuerungstechnik. Aber auch Modernisierungen, Erweiterungen und sicherheitstechnische Lösungen gehören zu diesem Leistungsbereich.

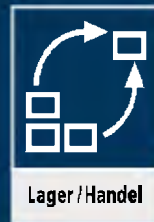

Neben einem breiten Spektrum von Serienkomponenten aus dem Hydraulikbereich, wie Ventile, Pumpen, DBV's, Verschraubungen usw. setzen wir auf unseren Leitfaden „das richtige Produkt an der richtigen Stelle“. Wir konfektionieren mit Ihrer Hilfe das richtige Produkt im Hinblick auf Kosten und Nutzen für Ihre Anwendung. Dieses gilt sowohl für den stationären als auch für den mobilen Bereich.



Neben dem bereits angesprochenen Engineering der Hydraulik bieten wir gleiches auch für den Bereich der Elektrosteuerung. Wir konzeptionieren Ihnen eine Neuanlage, einen Umbau oder auch eine Anlagenerweiterung inkl. passender Elektrosteuerung aus einer Hand.

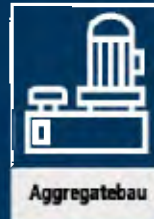

Durch unsere hohe und gut sortierte Lagerhaltung sind wir auch kurzfristig in der Lage Kleinaggregate nach Ihren Wünschen zu bauen und zu liefern. Wir arbeiten hier mit Komponenten, die eine Vielzahl an Variationsmöglichkeiten bieten und wir somit Ihren Wünschen gerecht werden können.



Wir übernehmen gerne das Projektmanagement für Vorhaben die in dem Bereich unserer Schwerpunkte angesiedelt sind, auch wenn sie über dieses Maß hinaus gehen. Ob Maschinenverlagerung, Zylinderreparatur an Großpressen oder Umbauarbeiten im Maschinenbau – wir koordinieren die notwendigen Arbeitsfolgen in Verbindung mit unserem Know-how.



Wir fertigen Rohrleitungswege bis Durchmesser 42 mm durch Biegen nach Kundenangaben oder als Service vor Ort. Leitungswege über 42 mm werden mit Rohrleitungsbögen durch WIG-Schweißen hergestellt.



Zu unserem täglichen Geschäft gehört schwerpunktmäßig die Betreuung unserer Kunden im eigenen Haus. Wir verfügen über zahlreiche voll ausgestattete Werkstattfahrzeuge um Ihnen jeden Service rund um die Hydraulik zu bieten. Ganz gleich ob Fehlersuche, Reparatur, Wartung oder Umbau, wir kommen kurzfristig zu Ihnen und helfen für einen gesicherten Betriebsablauf.



Wir fertigen alle gängigen Schläuche für die Stationär- sowie Mobilhydraulik im eigenen Haus. Dies kann geschehen nach Kundenangaben oder nach Muster. Bei größerem Bedarf fertigen wir die Schläuche vor Ort in Ihrem Haus.



Wir reparieren neben Ventilen, Druckspeichern, Steuerblöcken und Pumpen auch Zylinder und Hydromotore. Nach erfolgter Reparatur werden die Komponenten einer Leistungsprüfung unterzogen. Dies wird in Form von Prüfprotokollen dokumentiert. Durch unsere langjährigen Erfahrungen und guten Kontakten zu namhaften Herstellern sind wir häufig in der Lage schnell und kostengünstig eine Reparatur Ihrer Komponenten durchzuführen.



BF-Hydraulik gibt sein Wissen weiter. Wir schulen Ihr Personal in Ihrem Haus. Die Schulungen werden speziell auf Ihre Anwendungen und Anlagen angepasst. Anhand von aktuellen Fallbeispielen werden hydraulische Grundlagen vermittelt.